

CRITICAL APPRAISAL OF TRADITIONAL CONSTRUCTION TECHNIQUES IN HIMACHAL PRADESH

A DISSERTATION

*Submitted in partial fulfillment of the
requirements for the award of the degree
of*
MASTER OF ARCHITECTURE

BY

RIDHIMA MAHAJAN

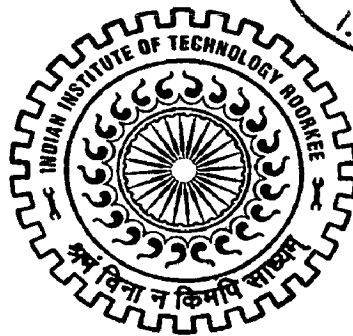
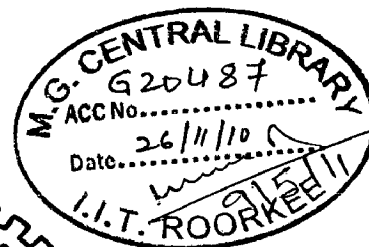

DEPARTMENT OF ARCHITECTURE AND PLANNING
INDIAN INSTITUTE OF TECHNOLOGY ROORKEE
ROORKEE-247 667 (INDIA)

JUNE, 2010

CANDIDATE'S DECLARATION

I hereby certify that the work, which is being presented in the dissertation, entitled **“CRITICAL APPRAISAL OF TRADITIONAL CONSTRUCTION TECHNIQUES IN HIMACHAL PRADESH”** in partial fulfilment of the requirement for the award of the degree of **Master of Architecture**, submitted to the Department of Architecture and Planning, Indian Institute of Technology Roorkee, is an authentic record of my own work carried out during the period from July 2009 to June 2010 under the supervision of **Prof. Pushplata**, Department of Architecture and Planning, Indian Institute of Technology Roorkee.

The matter embodied in this dissertation has not been submitted by me for the award of any other degree.

Place: Roorkee

Date:

Ridhima Mahajan
(Ridhima Mahajan)

CERTIFICATE

This is to certify that the above statement made by the candidate **Ms. Ridhima Mahajan** is correct to the best of my knowledge.

Place: Roorkee

Date: *30th June, 2010*

Pushplata

(Pushplata)

Professor,

Department of Architecture and Planning

Indian Institute of Technology Roorkee

Roorkee – 247667, India

ACKNOWLEDGMENT

William Shakespeare once said, “I can no other answer make, but, thanks, and thanks”. And no other words than thanks come to my mind also for all those who not only helped me in the due course of this dissertation but also in life helping me to be this person who has achieved all this and dreams of more. I take this opportunity to express my heartfelt gratitude to all of them without who I would not be here today

First and foremost I thank **my parents, brother and family** who not just helped me throughout my study but for being my support I can always fall back on. They have been there in times I needed to be listened to and when I needed to be talked to. It is needless to say that without them I would not be what I am today.

I would like to thank my guide and support **Prof. Pushplata**, without whose guidance and encouragement this dissertation would have never conceived. Her confidence in me and counsel showed me the path to follow at all times, pushing me to achieve higher heights. I cannot imagine completion of this work without her.

I would also like to extend my gratitude to **Prof. S.Y.Kulkarni, H.O.D. Deptt. Of Architecture, IIT Roorkee** for his kind help and advice at the various stages of my project. I would also like to take this opportunity to thank all the staff and faculty for their time and advice at all times without fail.

I also thank **Dr. S.K. Mishra** for his constructive critique and advice at different times. His valuable suggestions helped in carrying out this study smoothly and efficiently.

I would like to extend my thanks to **Shri Vijay Uppal, Chief Architect, Himachal Pradesh**, for his time and working experiences with traditional construction in Himachal. I also thank **Mr. Ashok Kumar CBRI** for his kind help and support. I also thank **Ar. Didi Contractor** for sharing her experiences and knowledge.

My deepest thanks goes to my friends **Deepthi, Dibini, Palash, Pushpal, Nithya, Shailza, Sunny, Yogesh and Dattatreya** for their suggestions and everlasting confidence in me. I extend special thank to my biggest supports **Preetika and Varun** for putting up with my erratic mood swings and listening to me at all times without fail.

At last I thank the almighty for being the light bearer in the times of testing and that power behind me that kept me going and will in future.

ABSTRACT

Increased awareness towards protecting our environment from the adverse affects of thoughtless development has led to the need of sustainable development. Buildings substantially influence the environment due to their higher consumption of energy and waste generation capacity. Technology employed for using these materials in the building influences energy requirements of the building in its lifetime. Thus, selection of appropriate building materials and technology, along with proper planning and design of built environment, are essential for a sustainable development.

Traditional buildings have withstood natural hazards and environmental impacts over centuries and sustained themselves in their original form. Many landmarks witness the century long knowledge which was originated from the needs of the people and the local conditions. The significance of traditional techniques in the hilly region increases due to the fragile ecology and geographical restrictions. But with the changing times and new developments in the technologies and materials, traditional materials and techniques have become redundant in the present context. Modern materials like brick and cement are gaining acceptance in the hills due to their easy availability. But these modern houses have not adapted themselves to the local climatic conditions and seismic restrictions.

So, there is increased demand for techniques which are sensitive to the local climate and geographical conditions and caters to the aspirations of the people. For the purpose of this study, the traditional and modern techniques prevalent in the region of Himachal Pradesh are studied and assessed for their appropriateness in the present context. Traditional knowledge of climate responsiveness and seismic suitability should be combined with latest materials and construction technology for a sustainable construction.

CONTENTS

CHAPTER 1- INTRODUCTION

1.1	BACKGROUND	1
1.2	NEED FOR STUDY	2
1.3	AIMS	3
1.4	OBJECTIVES	3
1.5	METHODOLOGY.....	3
1.6	METHODOLOGY FOR OBSERVATIONAL STUDY	5
1.7	SCOPE AND LIMITATIONS	7

CHAPTER 2- TRADITIONAL CONSTRUCTION TECHNIQUES : AN OVERVIEW

2.1	INTRODUCTION.....	8
2.2	TRADITIONAL CONSTRUCTION TECHNIQUES IN INDIA	9
2.2.1.	Traditional Construction in Hot Dry Climate	10
2.2.2.	Traditional Construction in Warm Humid Climate	11
2.2.3.	Traditional Construction in Composite Climate	13
2.2.4.	Traditional Construction in Cold Climate.....	14
2.3	IMPORTANCE OF TRADITIONAL TECHNIQUES.....	15
2.4	APPLICATIONS OF TRADITIONAL CONSTRUCTION TECHNIQUES.....	16
2.4.1	Application of Traditional Construction Techniques by Laurie Baker	17
2.4.1.1	Mud construction.....	17
2.4.1.2	Stone construction	20
2.4.1.3	Burnt bricks	22
2.4.1.4	Bamboo	24
2.4.2	Application of Traditional Construction Techniques by Hassan Fathy	25

2.4.3	Application of Traditional Construction Techniques by Centre For Vernacular Architecture	31
2.5	SUMMARY	31

CHAPTER 3- TRADITIONAL CONSTRUCTION TECHNIQUES IN HILLS

3.1	INTRODUCTION.....	33
3.2	TRADITIONAL CONSTRUCTION TECHNIQUES IN UTTARANCHAL.....	33
3.3	TRADITIONAL CONSTRUCTION TECHNIQUES IN KASHMIR	35
3.4	TRADITIONAL CONSTRUCTION TECHNIQUES IN ASSAM.....	37
3.5	TRADITIONAL CONSTRUCTION TECHNIQUES IN HIMACHAL PRADESH	38
3.5.1	Kath-Kunni Construction	40
3.5.2	Dhajji-Wall Construction	41
3.5.3	Wooden Construction	41
3.5.4	Dry Stone Construction	42
3.5.5	Mud Construction.....	43
3.6	SUMMARY	43

CHAPTER 4- PREVALENT CONSTRUCTION TECHNIQUES IN TRANS-HIMALAYAN REGION

4.1	INTRODUCTION.....	45
4.2	TRADITIONAL CONSTRUCTION TECHNIQUES IN TRANS HIMALAYAN REGION	45
4.2.1.	Analysis of Traditional Construction Techniques	48
A.	Climatic Response	48
B.	Material Suitability	49
C.	Structural and Seismic Stability.....	49

4.3 MODERN CONSTRUCTION TECHNIQUES IN TRANS- HIMALAYAN REGION	50
4.3.1. Analysis of Modern Constrecution Techniques	51
A. Climatic Response	51
B. Material Suitability	51
C. Structural and Seismic Stability.....	51
4.4 ALTERNATE CONSTRUCTION TECHNIQUES IN TRANS- HIMALAYAN REGION	52
4.4.1. Analysis of Alternate Construction Techniques	54
A. Climatic Response	54
B. Material Suitability	54
C. Structural and Seismic Stability.....	55
4.5 SUMMARY	55

CHAPTER 5- PREVALENT CONSTRUCTION TECHNIQUES IN HIGHER HIMALAYAN REGION

5.1 INTRODUCTION.....	56
5.2 TRADITIONAL CONSTRUCTION TECHNIQUES IN HIGHER HIMALAYAN REGION.....	56
5.2.1. Traditional Construction Techniques in Kinnaur.....	56
5.2.2. Analysis of Traditional Constrecution Techniques	59
A. Climatic Response	59
B. Material Suitability	59
C. Structural And Seismic Stability.....	59
5.2.3. Traditional Construction Techniques in Shimla.....	60
5.2.4. Analysis of Traditional Constrecution Techniques	62
A. Climatic Response	62

B. Material Suitability	62
C. Structural and Seismic Stability.....	63
5.2.5. Traditional Construction Techniques in Manali	64
5.2.6. Analysis of Traditional Construction Techniques	66
A. Climatic Response	66
B. Material Suitability	66
C. Structural and Seismic Stability.....	66
5.2.7. Traditional Construction Techniques in Chamba.....	67
5.2.8. Analysis of Traditional Construction Techniques	68
A. Climatic Response	68
B. Material Suitability	69
C. Structural and Seismic Stability.....	69
5.3 MODERN CONSTRUCTION PRACTICES IN HIGHER HIMALAYAN REGION	69
5.3.1. Analysis of Modern Construction Techniques	70
A. Climatic Response	70
B. Material Suitability	70
C. Structural and Seismic Stability.....	70
5.4 ALTERNATE CONSTRUCTION TECHNIQUES IN HIGHER HIMALAYAN REGION	71
5.4.1. Analysis of Alternate Construction Techniques	71
A. Climatic Response	71
B. Material Suitability	71
C. Structural and Seismic Stability.....	72
5.5 SUMMARY	73

**CHAPTER 6- PREVALENT CONSTRUCTION TECHNIQUES IN LOWER
HIMALAYAN REGION**

6.1	INTRODUCTION.....	74
6.2	TRADITIONAL CONSTRUCTION PRACTICES IN KANGRA.....	74
6.2.1.	Analysis of Traditional Constrcution Techniques	75
A.	Climatic Response	76
B.	Material Suitability	76
C.	Structural and Seismic Stability.....	76
6.3	MODERN CONSTRUCTION PRACTICES IN LOWER HIMALAYAN REGION	76
6.3.1	Analysis of Modern Constrcution Techniques	77
A.	Climatic Response	77
B.	Material Suitability	77
C.	Structural and Seismic Stability.....	77
6.4	ALTERNATE CONSTRUCTION PRACTICES IN LOWER HIMALAYAN REGION	77
6.4.1	Analysis of Alternate Constrcution Techniques	79
A.	Climatic Response	79
B.	Material Suitability	79
C.	Structural and Seismic Stability.....	79
6.5	SUMMARY	80

CHAPTER 7- CONCLUSION RECOMMENDATION AND FUTURE POTENTIAL

5.1	INTRODUCTION.....	81
5.2	CONCLUSION	81

5.3 FACTORS GOVERNING THE APPLICABILITY OF TRADITIONAL CONSTRUCTION TECHNIQUES IN MODERN CONTEXT	82
5.4 RECOMMENDATIONS IN FORM OF ALTERNATE CONSTRUCTION TECHNIQUE	84
5.5 FUTURE POTENTIAL	86
REFERENCES.....	87
BIBLIOGRAPHY.....	88

LIST OF FIGURES

Figure 1.1 Diagram showing methodology adopted for this study.....	5
Figure 1.2 Diagram showing methodology adopted for Observational Survey	6
Figure 2.1 Climatic zones across India.	10
Figure 2.2 Section across houses in Rajasthan showing shading with courtyards.	11
Figure 2.3 Mud house in Rajasthan.	11
Figure 2.4 Movement of air in traditional house in warm humid climate	12
Figure 2.5 A house in hot humid climate of Kerala.....	12
Figure 2.6 Traditional house in composite climate.....	13
Figure 2.7 A house in cold climate of Kashmir valley	14
Figure 2.8 Traditional house in Assam.....	15
Figure 2.9a Formwork for construction by ramming mud	17
Figure 2.10 Laying cob wall and leaving the openings	18
Figure 2.11 Laying Cob wall	19
Figure 2.12 Building with sun dried bricks	19
Figure 2.13 Structure of Wattle and Daub wall	20
Figure 2.14 Methods of mud wall protection.....	20
Figure 2.15 Proper bonding in Stone	21
Figure 2.16 Stone blocks laid with proper bonding.....	21
Figure 2.17 Round stones used in wall construction	22
Figure 2.18 Small stones used to produce blocks	22
Figure 2.19 Rat- trap bond.....	23
Figure 2.20 Minimising use of plastering	24

Figure 2.21 Use of Jali	24
Figure 2.22 Use of bamboo as reinforcement in foundation and roof	25
Figure 2.23 View of arched hall built with mud bricks.	26
Figure 2.24 Site plan of Gournna	27
Figure 2.25 Movement of air through a typical traditional house	28
Figure 2.26 Gournna mall : Brilliant use of Vaults and domes	28
Figure 2.27 View of the court and the on site brick making	28
Figure 2.28 View of screen at Suheymi house	29
Figure 2.29 View of typical Mashrabiyyah	30
Figure 2.30 Section across house and across courtyards	30
Figure 2.31 Traditional materials used in resort	31
Figure 3.1 A typical multi-storeyed house in Uttarakhand	34
Figure 3.2 Bonding in wooden members in traditional construction	34
Figure 3.3 Stone houses in Kumaoni village	35
Figure 3.4 Traditional house with Dhajji dewari construction	36
Figure 3.5 Traditional house with Taq construction and corner detail	37
Figure 3.6 Laying Ikara within wooden panels	38
Figure 3.7 Traditional Assam type house	38
Figure 3.8 Physical map of Himachal Pradesh	39
Figure 3.9 Typical house in Kullu and detail of alternate layers of wood and stone	40
Figure 3.10 Wooden bracing in Dhajji wall system and system of wooden framing	41
Figure 3.11 Typical house with wood construction	42
Figure 3.12 Typical construction with dry rubble masonry using dressed stones	42

Figure 3.13 Mud houses in Lahaul and a typical section of mud wall	43
Figure 4.1 Typical house in Lahaul, Ground floor plan	46
Figure 4.2 Typical house in Lahaul, Upper floor plan.....	46
Figure 4.3 Typical house in trans-Himalayas	47
Figure 4.4 Section through the mud wall and details of roof.....	47
Figure 4.5 Roof detail	48
Figure 4.6 Detail of Earthquake band between plinth and wall.....	49
Figure 4.7 Earthquake failure in two storeyed mud walls	50
Figure 4.8 A modern building in Lahaul	50
Figure 4.9 Wall in North direction.....	52
Figure 4.10 walls in east and west	53
Figure 4.11 Window detail on South	53
Figure 5.1 Traditional house in Kinnaur with Kath Kunni construction	57
Figure 5.2 Typical corner detail in Kath Kunni construction	57
Figure 5.3 Laying wall in alternate layers of wood and stone	58
Figure 5.4 Section of typical house in Kinnaur	58
Figure 5.5 Provision of alternate bands provide seismic stability	60
Figure 5.6 Corner detail	61
Figure 5.7 Dhajji wall frame	62
Figure 5.8 Behaviour of Dhajji wall under seismic loads.....	63
Figure 5.9 Typical wooden house in Manali	64
Figure 5.10 Wooden frame and construction.....	65
Figure 5.11 Section through typical wooden house.....	65

Figure 5.12 Failures in wooden frame due to inadequate nosing	66
Figure 5.13 A typical House in Chamba.....	67
Figure 5.14 Detail of the column	67
Figure 5.15 Section of typical house in Chamba	68
Figure 5.16 Damage caused due to collapse of stone wall	69
Figure 5.17 Typical modern concrete house in Higher Hiamalayas.....	70
Figure 5.18 Cement concrete as an infill in wooden frame	71
Figure5.19 Improper provision of braces.....	72
Figure 6.1 A typical traditional mud house	74
Figure 6.2 Section through mud wall.....	75
Figure 5.3 Failure in mud walls	76
Figure 6.4 A modern building in Kangra valley.....	77
Figure 6.5 View of alternate mud house.....	78
Figure 6.6 Floor from below	79
Figure 7.1 Sketch showing use of stone blocks, concrete blocks and prefabricated beams as a potential construction technique	85

CHAPTER 1: INTRODUCTION

1.1 BACKGROUND

Construction techniques and materials employed in buildings play a significant role in their safety, response to local environmental conditions and their cost effectiveness. Construction industry is one of the highest consumers of energy. Material used for construction has a direct impact on the energy consumption and consequently affect the environmental impact of the building. Sustainability is the foremost concern in the world today due to impending climatic change. Sustainable development takes a whole new magnitude in the fragile ecological context of the hill regions. Hilly regions are not only fragile but also experience harsh climates and are susceptible to environmental impacts like landslides, earthquakes, etc. In such a scenario, planning, designing and construction of new settlements need to be a response to the climatic conditions and disaster vulnerability of hills.

Traditional construction techniques have evolved over centuries as a response to the varied climates and availability of materials. They have withstood the test of times, resisting natural hazards and environmental impacts. The traditional construction techniques employed in hill region use the local materials and the expertise of the ages to minimise their impact on the ecology. The traditional buildings in the hills seem to have sprung from the ground, merging with the landscape of the hills. F.L.Wright defined traditional buildings as

“Folk building growing in response to actual needs, fitted into environment by people who knew no better than to fit them with native feeling.” [1]

Whereas the impact of construction practices prevalent in hills nowadays which are no different from the construction in plains due to easy availability of cement and bricks, is more than the transformation in the serene and pleasant visuals of the hills. The inefficient performance of these building practices in terms of energy and stability against natural hazards is a lesson to learn. While the buildings using traditional construction techniques seem to have provided answers to the local needs. Increased exposure to new materials and technologies and consequently the aspirations of the people have undermined the use of traditional techniques. However innovations in technologies and new materials that more efficient, better looking and at times even cost effective can provide an solution to the impending question of how to create a sustainable environment.

1.2 NEED OF THE STUDY

The cities are moving towards modernization where the old construction practices and techniques are fast replaced by the new buildings constructed with modern materials. Traditional construction techniques have evolved from the knowledge and understanding of the local climatic conditions, local materials and needs of people passed on for centuries. Traditional architecture is meant to create harmony between dwellings, dwellers and the physical environment. Use of locally available material in the traditional construction is a sustainable practice since local materials use less embodied energy than the imported materials.

Didi contractor explained the significance of traditional construction practices, *“.....builders in the past used simpler technologies and had to comply with ecological constraints and rely on local raw materials. Thus, sustainable building methods were developed from necessity as buildings were designed with the local context in mind. These lessons, as well as others, can be tapped in places where indigenous building is remembered and practiced.”* [2]

As an effort to adopt lessons from traditional techniques, many studies and researches have been done to assess the applicability of these traditional construction techniques in the “modern” times. Architects like Laurie Baker and Didi Contractor have been employing traditional techniques in their designs. Even though techniques like Dhajji wall construction have been successfully employed in reconstruction works in disaster hit areas, the most commonly used construction practices are adopted from the plains. The choice of these techniques is in light of easy availability of materials like cement, brick etc. irrespective of the fact that these practices are not sustainable in context with hilly areas. These materials are transported to larger distances and are not in harmony with the climatic conditions. The inadequate attention to detailing, extensive use of cement and bricks and poor workmanship has resulted in a vulnerable built fabric due to little importance given to construction details and inappropriateness of new technologies. Also there is a decline in the traditional knowledge of the construction techniques due to unavailability of traditional materials like slate, wood, etc. and depleting traditional workmanship. In order to develop practices for performance in terms of sustainability, structural safety and economic viability there is a need to assess the traditional construction practices which have proven themselves to be sustainable for the hills along side the modern practices.

1.3 AIMS

To explore the various construction techniques in traditional buildings in Himachal Pradesh and assess their application in present scenario.

1.4 OBJECTIVES

- i. To study impact of geographical and climatic features of on traditional construction techniques.
- ii. To understand the vernacular construction techniques employed in domestic buildings in different hilly areas with special reference to Himachal Pradesh.
- iii. To study shortcomings of the new construction techniques vis-à-vis the traditional techniques prevalent in Himachal Pradesh.
- iv. To assess the potential application of the traditional construction techniques in the present scenario.

1.5 METHODOLOGY

In order to achieve the above stated objectives, the following methodology shown in fig. 1.1 is adopted

1. Literature Review

The background study for the construction practices adopted in the state, both traditional and modern has been done through the study of various literature. Relevant literature have been revied so as to overview the traditional construction techniques for their responsiveness to local context and understand the issues involved in reviving traditional techniques in modern context.

- i. Study the impact of climatic and geographical factors on the various construction techniques adopted in the country.
- ii. Study the various modern building practices evolved from the traditional techniques as case studies
- iii. Identify and study various traditional techniques adopted in different regions of the state.

- iv. Study structural stability and seismic performance of buildings using traditional techniques

2. Observational Study

The various construction practices studied in the literature are validated through survey of various regions in the state. The schematic observational survey was done to fulfill the following objectives.

- i. Identify and study most prevalent traditional construction practices in different regions.
- ii. Study choice and use of the materials in the traditional buildings of the region.
- iii. Study appropriateness of these construction techniques for different climatic regions.
- iv. Study various prevalent modern building practices in the regions and study their appropriateness.
- v. Study issues/ problems related to adoption of vernacular construction techniques in the region

3. Conclusion & Recommendations

Based on the literature study and the observational study, traditional and modern construction techniques have been assessed for their appropriateness in the different region of Himachal Pradesh and conclusions and recommendations are made in the form of application of traditional construction practices using modern materials.

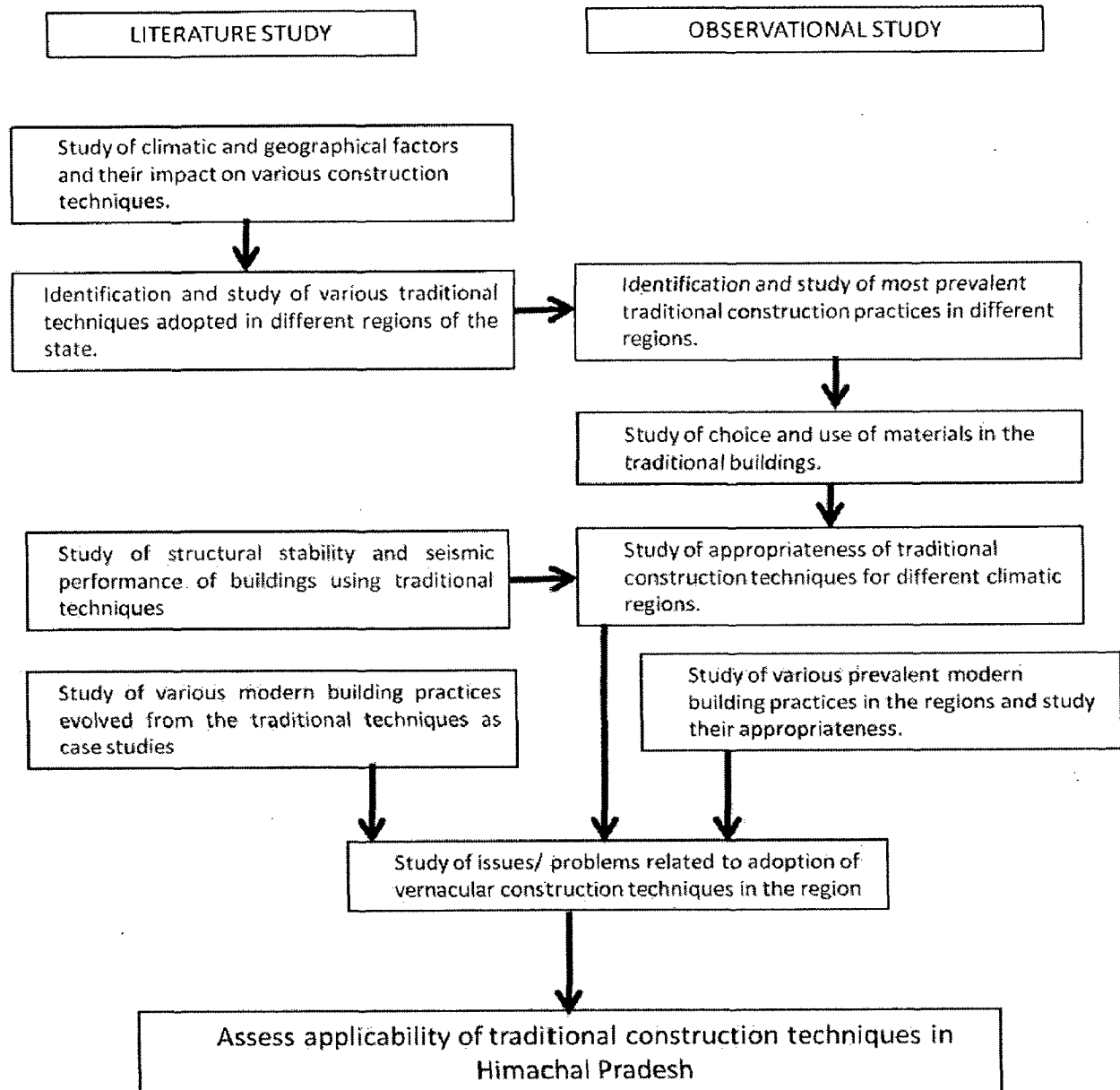

Figure 1.1 Diagram showing methodology adopted for this study

1.6 METHODOLOGY FOR OBSERVATIONAL STUDY

A survey of the prevalent construction techniques was essential to fulfil the aim of the research. For the same, Himachal is broadly classified into three regions, the trans-Himalayan region, the higher Himalayan and the Lower Himalayan region depending upon their elevations. The construction practices employed in three regions are categorised as: Traditional, Modern and Alternate. For each region, the traditional construction practices are identified through the literature survey. Typical examples of traditional and modern techniques in the three regions are surveyed through observational study. (fig. 1.2) Case

studies are done to identify and analyse alternate construction techniques which employ modern materials in combination with traditional techniques. Effectiveness of these construction practices is evaluated through observational study and through interviews from the users as well as professionals under design criteria of climatic response, material suitability and structural and seismic suitability.

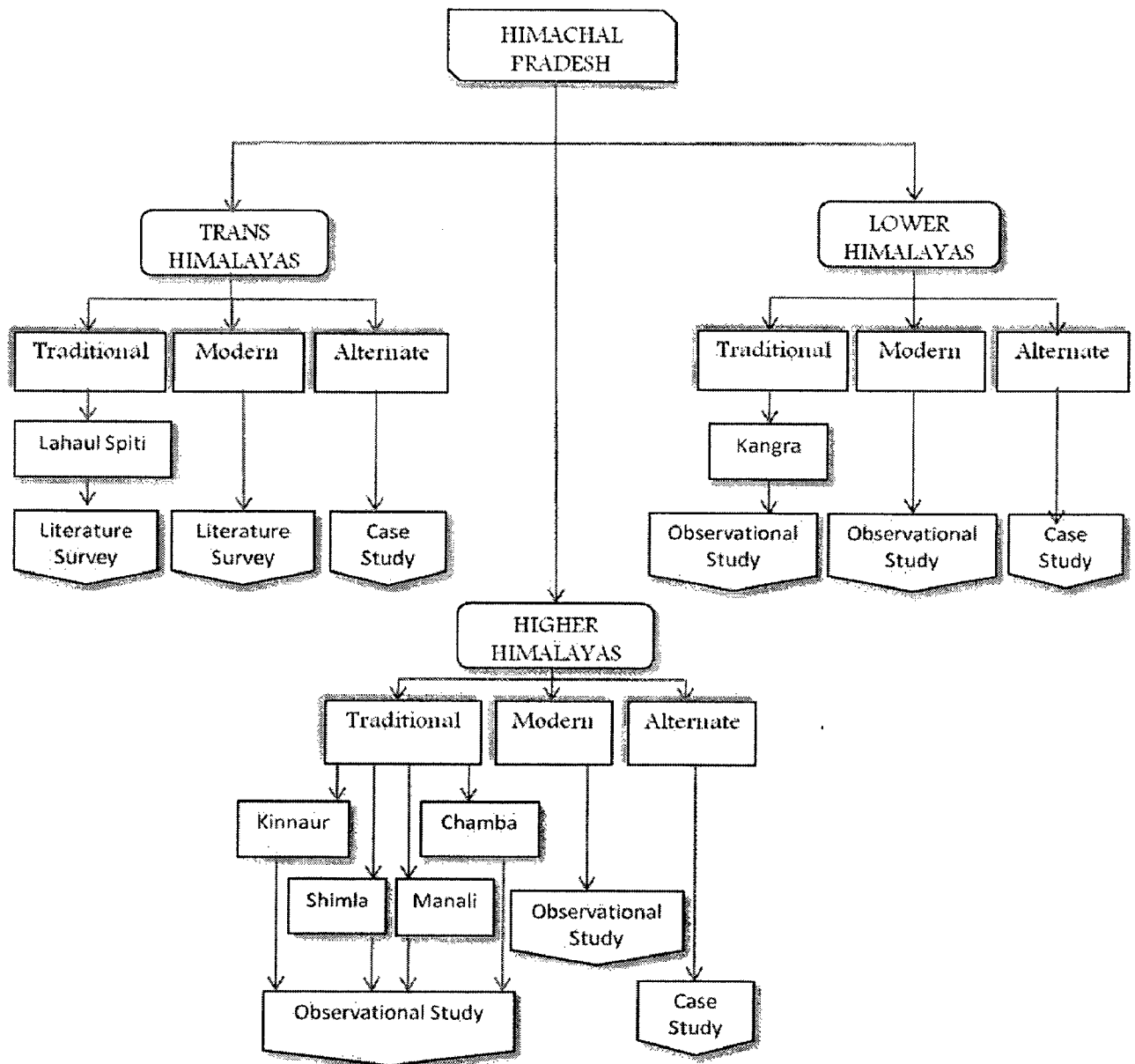

Figure 1.2 Diagram showing methodology adopted for Observational Survey

1.7 SCOPE AND LIMITATIONS

1. This research is primarily based on the study of vernacular construction techniques of Himachal Pradesh.
2. The scope of the work is limited to the predominant construction techniques of building types in the region.

CHAPTER 2: TRADITIONAL CONSTRUCTION TECHNIQUES: AN OVERVIEW

2.1 INTRODUCTION

Traditional architecture is defined as “*Forms which grow out of the practical needs of the inhabitants of a place and the constraints of the site and climate.*”[3] Each region of the world employs its own techniques and designs in its buildings that are best suited to that particular region and that manifest the region’s cultural patterns. Limited access to materials and technology resulted into wisdom to use the local materials and evolve techniques to cater to people’s needs. The environmental and cultural conditions of the region played an important role in the development of these techniques. When architects made note of the reduction of temperature created by the huge stonewalls and their shadows, thick walls made of stuccoed brick were constructed in Rome which allowed shadows of the walls keeping the city cool during the midday hours. The stuccoed walls are an example of climate-responsive architecture, or architecture that is constructed and built with designs that make use of the surrounding climate and its natural effects.

Traditional construction practices have been passed over the generations as a bank of knowledge, experience and wisdom of centuries. The creative imagination and the inventiveness of self-taught builders resulted in residences which were exceptionally suitable for life, work and the environment. This was demonstrated not only in the appearance and floor plans of these houses, but also their construction details. In building residences, traditional builders estimated the climatic conditions and the nature of the soil with remarkable skill. By using materials found in the surroundings, they created architectural styles which were specific to a given region. The financial status, the professions and life of the residents, and the cultural trends in different times in history had significance in building these residences. The building was also a response to the people’s status in the society. This is evident not only in the lavish decorations of the houses but also the planning and construction of their residences.

R.W. Brunskill’s words about traditional architecture recount the development of traditional techniques as “*...a building designed by an amateur without any training in design; the individual will have been guided by a series of conventions built up in his locality, paying little attention to what may be fashionable. The function of the building would be the dominant factor, aesthetic considerations, though present to some small*

degree, being quite minimal. Local materials would be used as a matter of course, other materials being chosen and imported quite exceptionally.” [1]

In spite of all the varied techniques across the world, there is uniformity in construction with similar climatic conditions. Typically, a house in hot arid climate is distinguished by large courtyards serving as reservoirs of cool, fresh air as seen in examples from Marrakech, Morocco; Tunis, Tunisia; and Damascus, Syria; Iran, Rajasthan, India etc. while the houses in humid climate are unique in their bamboo construction with large steep sloping roofs. The traditional construction in hills is marked by compact plan with wood and stone construction.

This chapter discusses the typical construction techniques adopted in various regions across India. These traditional practices not only give an insight into the knowledge of the climate responsive architecture followed through centuries but also create background to the appropriateness of these traditional construction practices for a typical climate. This chapter also discusses the various attempts made to revive the traditional construction practices and materials to suit the present social, economic and cultural needs.

2.2 TRADITIONAL CONSTRUCTION TECHNIQUES IN INDIA

The diverse climatic and cultural base of India has resulted in a wide range of architecture across the country. The architectural design and construction techniques reflect the rich diversity of Indian climate, locally available building materials, and the intricate variations in social customs and craftsmanship. These traditional techniques have developed over time, shaped by the many influences along its millennia-old past.

Despite the regional diversity in architecture in the country, traditional construction can be classified into three categories: kachcha, pukka and semi-pukka. [4]

- Kachcha building is made up of unprocessed natural material such as mud, cane, bamboo, thatch and wood available in the vicinity. These kinds of buildings have specific form and the cost of construction is minimal.
- Pukka buildings are made up of stone, bricks, tiles, metal or other processed materials and surkhi or mortar is used for binding. These structures are expensive and do not require regular maintenance.

- Semi-pukka buildings are a combination of kachcha and pukka style. Common building materials in hilly areas are rocky rubble, ashlar, stone pieces, bamboo, wood and cane. In plain areas mud-blocks or sun-baked bricks are widely used for construction.

Vernacular architecture varies substantially for regions of hot climate and regions of cold climate. In many areas same materials are used, but the way in which these materials are used in each climate makes them unique. India experiences six climates: cold and cloudy, warm and humid, cold and sunny, hot and dry, moderate and composite as shown in the fig. 2.1. The architecture in these regions is distinct from each other and a response to the climate of the region. The typical features of buildings built traditionally for hot dry, hot humid, composite and cold climate are discussed in detail below.

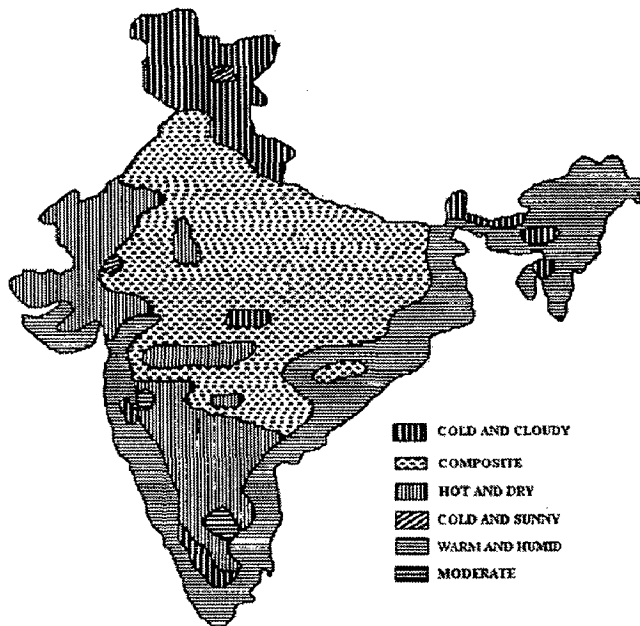

Figure 2.1 Climatic zones across India.

Source: Singh Manoj Kumar et.al. (2008) "Bioclimatism and vernacular architecture of north-east India" Science direct

2.2.1. TRADITIONAL CONSTRUCTION IN HOT DRY CLIMATE

In a hot and dry climate, protection from harsh sun is a major design criterion. The buildings are designed with rooms built around a courtyard which cuts off the sun thus shading the inner spaces. The thick walls, high roofs and small openings are distinguished features of houses in hot dry climate. The thick exterior walls allow time

lag for the heat to enter thus help to keep internal temperatures from rising above the outside surface temperature. Materials like mud and stone provide a large thermal mass and greater time lag for this purpose. The height of the living spaces is large to allow the warm air to rise up to cool the living area as shown in fig. 2.2. Windows are small to protect from the sandstorms and arranged so as to help air stream to be directed into rooms for ventilation. The use of shading devices is also a unifying feature. The form and construction of these houses makes them resistant to wind pressures and earthquakes. A typical village house in hot and dry climate is shown in the fig. 2.3.

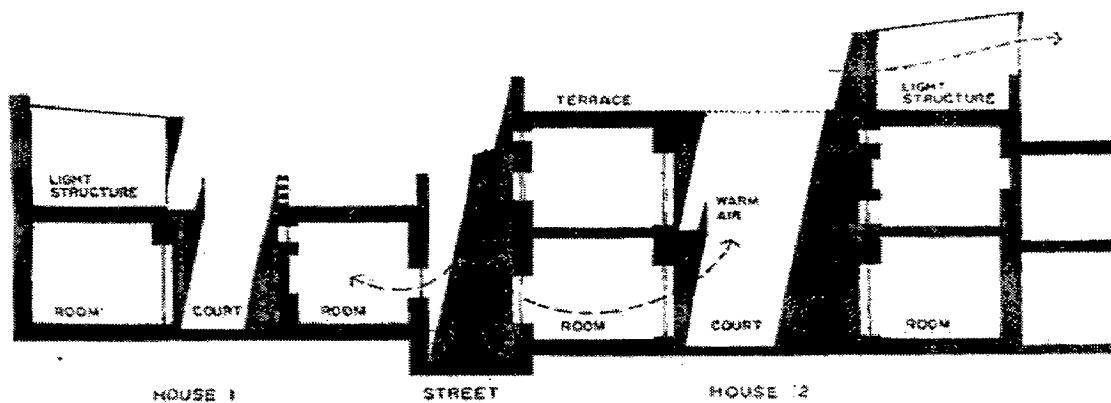

Figure 2.2 Section across houses in Rajasthan showing shading with courtyards.

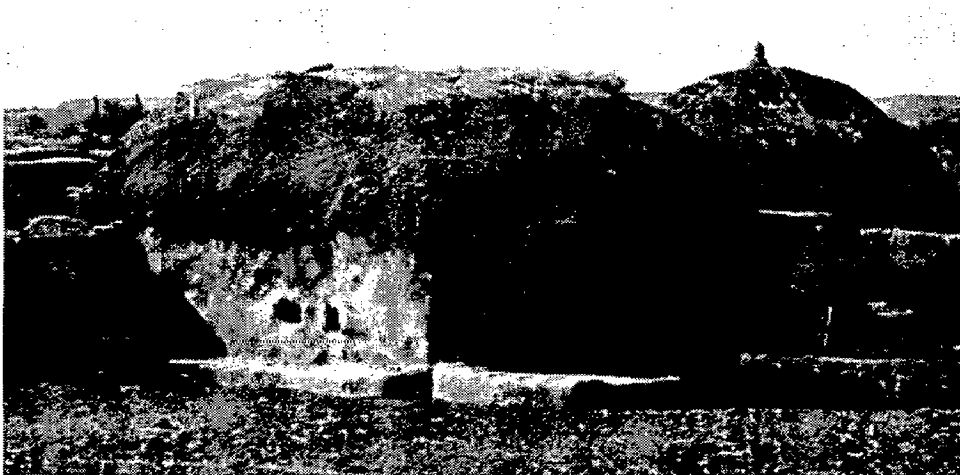

Figure 2.3 Mud house in Rajasthan.

Source: <http://designflute.wordpress.com/2007/09/30/house-of-mud/>

2.2.2. TRADITIONAL CONSTRUCTION IN WARM HUMID CLIMATE

In all the houses in warm humid climate, it is important to design buildings whose structure and interior are best able to keep warm air out. The buildings are raised above

ground on brick masonry free from watery and damp ground which improves air movement in the upper floors, therefore, keeps the inhabitants cooler. The high roofs and ventilation provisions at the top throws the hot air out. (Fig. 2.4)

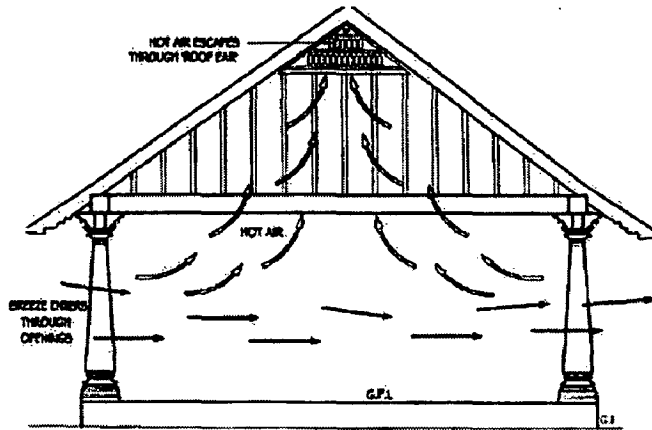

Figure 2.4 Movement of air in traditional house in warm humid climate

Locally available material like bamboo, cane, mud, lime and brick are used in different proportions effectively and efficiently. The typical traditional building found in Kerala in warm humid climate is constructed with a wooden framed structure since it is hard, resistant to moisture and has poor thermal conductivity and also creates a light structure. (Fig. 2.5) The first floor is completely constructed of wood. Surkhi (mixture of lime, brick powder, sand and jaggery, etc.) is used to fix the bricks in pukka buildings. In some of houses half of the walls are constructed with brick masonry and above that it is wooden construction.

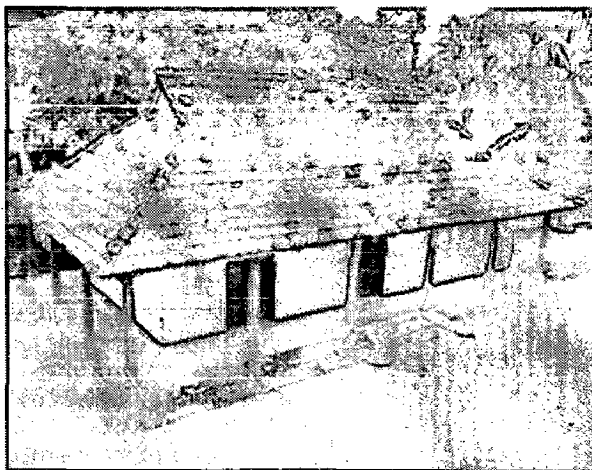

Figure 2.5 A house in hot humid climate of Kerala

Source: <http://hallosushant.blogspot.com/2009/05/traditional-kerala-homes-narikkottilam.html>

2.2.3. TRADITIONAL CONSTRUCTION IN COMPOSITE CLIMATE

The buildings built in a composite climate, where the summers are hot and dry while the winters are cold, must allow dissipation of heat during the summer days and prevent heat loss during the winters. The common design features in the traditional buildings in composite climatic zone are thick walls, massive columns, and heavy roof with maximum openings facing windward direction though openings were limited in number and size not only to reduce the heat gain but also to protect from the dust. These features are evident in the fig. 2.6 below showing a traditional house in Delhi region. The western side of the buildings was generally provided with thicker walls to minimise the heat gain. Many traditional buildings were designed with seasonal living spaces like the ground floor or the northern side of the house was used for sleeping in summers which the warmer southern side and the upper floors were used in winters. Another design feature to control the entry of sun rays in summers and allow the sun inside in winters was longer eaves or a corridor on the periphery of the rooms on the first floor to act as buffer. Various traditional buildings also have small parapet walls made of wood or brick with fenestrations to allow unobstructed flow of wind on the roof and corridors. Use of shading devices like chajjas is a common element in the traditional buildings. Traditional buildings have also used the elements of landscape to their benefit. Using the water body on the windward side or planting deciduous trees to allow sun inside in winters are some of the measures that were used to maintain comfortable conditions inside the house all round the year.

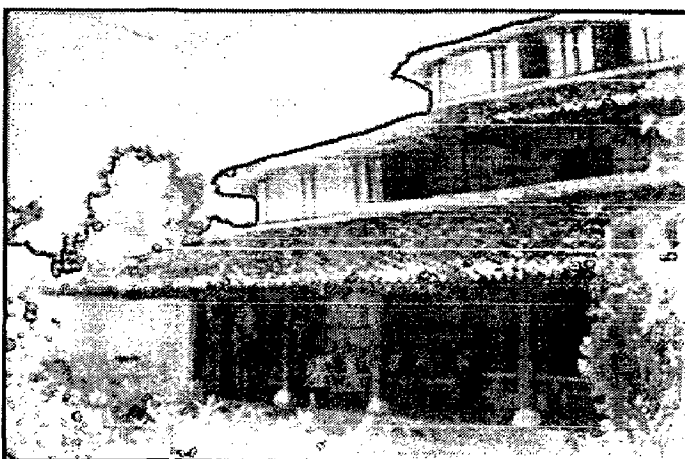

Figure 2.6 Traditional house in composite climate

Source: <http://www.archinomy.com/case-studies/677/traditional-dwelling-in-delhi>

2.2.4. TRADITIONAL CONSTRUCTION IN COLD CLIMATE

In cold climate, traditional buildings were built so as to achieve a warmer inside temperature than the outside. The key to reaching that goal is good insulation and sunshine exposure which helps to keep the warm air inside the building. To minimize and reduce heat loss many rooms contain low ceilings, thick stonewall, small windows, and centrally located heating. The difference between thick walls in cold and hot climates is that in hot climates the walls outside are meant to shade the interior from the intense heat, whereas, in cold climates the walls inside are meant to insulate and keep heat in. In India, the cold climate is majorly experienced in the hilly terrain of the Himalayas like Jammu and Kashmir, Himachal Pradesh, Uttarakhand and some of north eastern states. A traditional building in hills is usually built just below the brow of a hill on the southward slope. The buildings are oriented towards the south slope for maximum sun exposure. This way the building is protected by the hill and by surrounding shelterbelts of trees.

The traditional buildings in the higher ranges of Himalayas vary from those in the lower ranges. The buildings built in the regions susceptible to snowfall are built on a higher plinth of stone masonry. The walls are made of wood and stone and wooden pillars as the structural members. (Fig. 2.7) The houses are compactly designed with the upper floors used for living. The houses are provided with smaller openings.



Figure 2.7 A house in cold climate of Kashmir valley

Source: <http://eatanddust.wordpress.com/2009/07/12/eat-and-a-lot-less-dust/>

The traditional houses in the lower Himalayan region like hills of Assam seem to have developed to counteract the heavy rainfall and the cold winters. A typical house in

Assam is built over half a brick wall plinth which interfaces with the timber frame panels to contain the upper part of the wall. (Fig. 2.8) The wall is divided into panels with wooden frame and laced with bamboo with reed cut into the size of panel and placed longitudinally and covered with three layers of mud mortar.

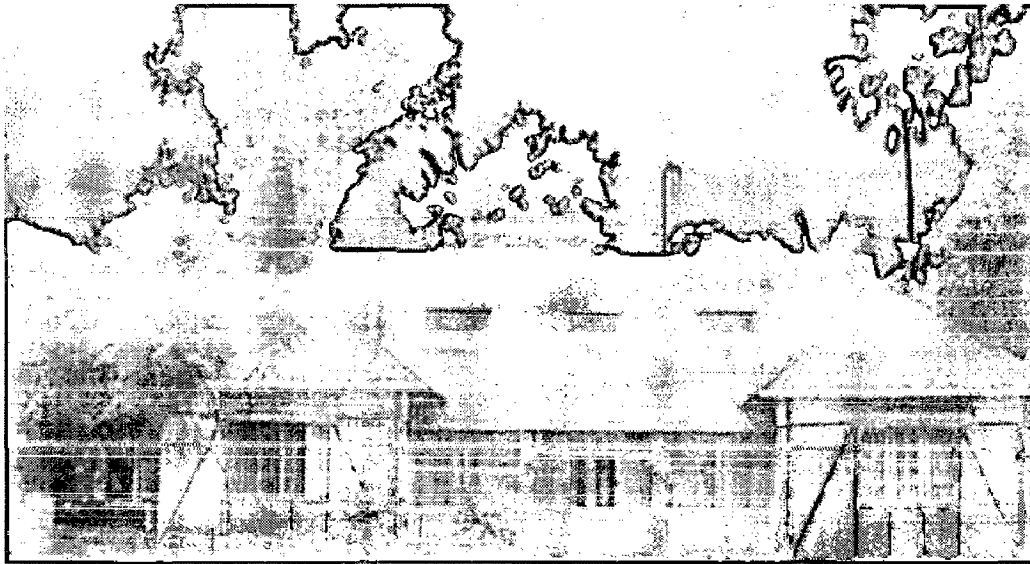

Figure 2.8 Traditional house in Assam

Source: <http://photos.merineews.com/newPhotoLanding.jsp?imageID=13454>

The construction techniques employed in hills with reference to hills in India including Uttaranchal, Kashmir, Assam and Himachal Pradesh will be discussed in detail in the next chapter.

2.3 IMPORTANCE OF TRADITIONAL TECHNIQUES

Traditional architecture sets an example of harmony between dwellings, dwellers and the physical environment. Traditional buildings take their inspiration from their surroundings and merge with the nature rather than impose on it. The wisdom of traditional practices has been highlighted by Paul Oliver "*Vernacular architecture, given the insights it gives into issues of environmental adaptation, will be necessary in the future to ensure sustainability in both cultural and economic terms beyond the short term.*"[1]

But traditional techniques are often dismissed as crude and unrefined and ignored in modern times. At times, these techniques are seen as buildings for poor. However, many

architects and agencies have employed these traditional techniques for constructing buildings which are sustainable and energy efficient in addition to their cost efficiency. Around the world architects are continuously expanding and inventing new ideas that make use of the natural environment and its extraordinary effects on the way humans live comfortably in their homes and workplaces. Architects are using these techniques as a response to the need for a sustainable development.

Buildings using traditional construction techniques not only provided answers to the local needs but these have also withstood the test of times. The traditional builders evaluated the site conditions with utmost precision. They have been constructed with the knowledge of the natural hazards like earthquake, floods, etc. Whilst the buildings constructed with conventional techniques do not use the traditional knowledge and the builders do not have ample knowledge about the conventional techniques thus making these buildings vulnerable to these hazards. As mentioned by Laurie Baker regarding traditional houses in Kerala, “.....*these houses were built in areas that faced devastating cyclones every year and very often this type of indigenous architecture is a better chance of survival than the more 'proper' type of structure of bricks, mortar and reinforced concrete slabs.*” [5]

Although, it may not be appropriate to adopt these models as readymade solutions for modern architecture. An advanced technical capability and a new cultural context do not allow a return to these old-fashioned architectural forms. But one must learn a lesson from the approach of the builders who acknowledged the interdependence of human beings, buildings and physical environment. As Didi Contractor quotes “*Sustainable design and ideology which embraces the natural processes of the earth as its reality must replace conventional design practices.*” [6]

2.4 APPLICATIONS OF TRADITIONAL CONSTRUCTION TECHNIQUES

As an effort to showcase the relevance of traditional construction practices and materials in the present context, many architects and organisations have been working to revive the age old knowledge to suit the present needs of a sustainable environment. The significant techniques used and employed by Laurie Baker, Hassan Fathy and Centre for Vernacular Architecture are discussed below.

2.4.1 APPLICATION OF TRADITIONAL CONSTRUCTION TECHNIQUES BY LAURIE BAKER

Viability of the indigenous architecture and methods to deal with the climatic conditions, local geography and topography along with natural hazards and accommodate requirements of local religious, social and cultural patterns of living is highlighted by Laurie Baker in his works in Trivandrum, Kerala and in Uttarkashi. Awareness for cost-effective energy-efficient architecture is widely spread by him through his organization, COSTFORD (Centre of Science and Technology for Rural Development). He summarized his experience as *“I was increasingly fascinated by the skills of ordinary, poor, village people working with the most unpromising and crude materials with apparently almost no recognizable tools to make useful everyday buildings and articles.”*[7] His studies showed that these techniques are most appropriate to the conditions. Thus in his designs, he uses the materials which are found natively around the region where construction is going to take place. Different techniques using different building materials adopted by Laurie Baker including mud construction, stone construction and construction with burnt bricks are discussed in detail below.

2.4.1.1 Mud construction

Various techniques using the mud as a building material like rammed earth construction, cob system, adobe construction and wattle and daub ,method are adopted by Laurie baker in his buildings are described below.

- **The system of constructing walls by ramming:**

This system works on the principle of ramming earth by thus making compact walls. For this, one requires wooden equipment including two parallel planks held firmly apart with metal rods and bolts. Mud is thrown into the space between the planks and then rammed down with either a wooden or a metal ramrod. Once a layer is completed and has hardened, the planks are released, taken high up and the next layer is installed. (Fig. 2.9a & 2.9b)

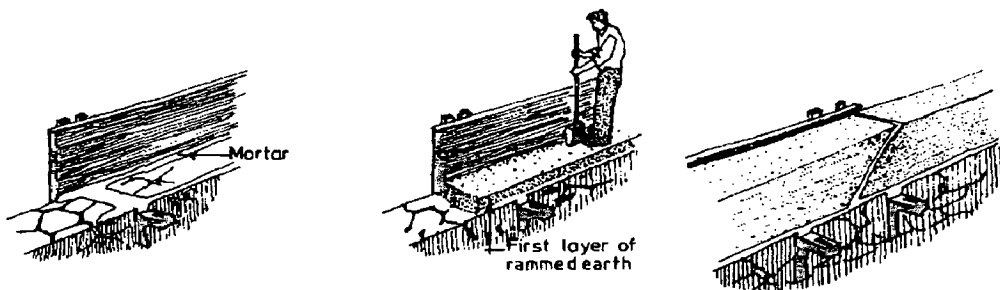

Figure 2.9a Formwork for construction by ramming mud

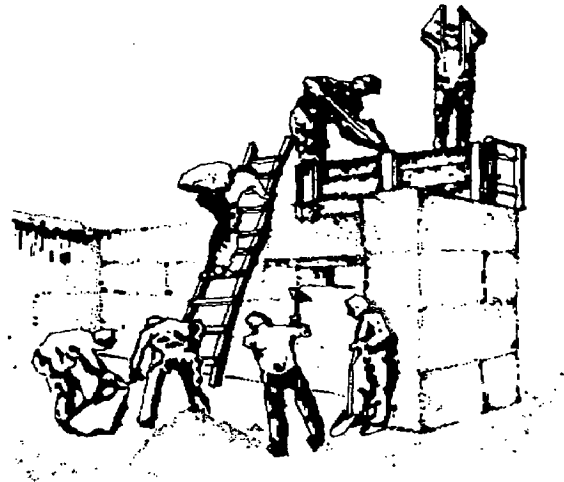
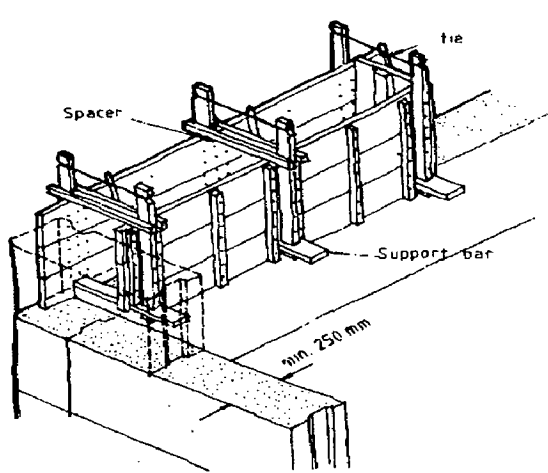

Figure 2.9b System for constructing walls by ramming

Source: <http://www.fao.org/docrep/s1250e/s1250e0j.htm>

- The “cob” system:

In this system, large lumps of mud mixed with sand, fibre (generally straw), and water are moulded in the shape of a huge elongated egg, about 6 inches in diameter and about 12 to 18 inches in size. (Fig. 2.10) Rows of cobs are placed over each other to make a wall. Gaps and holes are filled and the wall is slammed down at the sides. (Fig. 2.11) The cob system is the easiest for those constructing a mud house for the first time and no special tools, equipment or moulds are required. Such a construction is beneficial for both cold and hot climate for its large thermal mass.

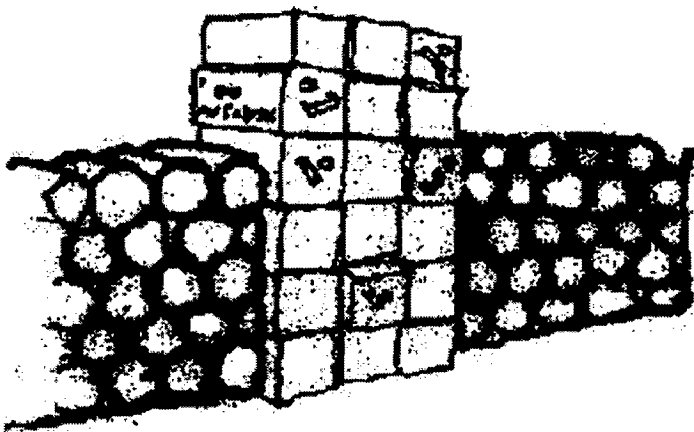

Figure 2.10 Laying cob wall and leaving the openings

Source: Baker Laurie (1986) Mud, COSTFORD

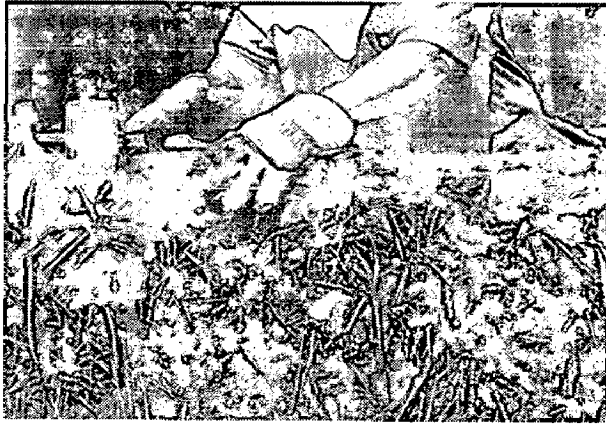

Figure 2.11 Laying Cob wall

Source: http://en.wikipedia.org/wiki/File:Cob_wall_mud_construction.jpg

- **Adobe or sun-dried brick systems:**

In this type of construction technique, moulds of brick are filled with the right mix of wet mud. The mould is then removed and the brick dried in the sun. Once the bricks are dried, they are laid in masonry with mud mortar. (Fig. 2.12) Mud walls are plastered with mud mortar only on the exterior surface. Compressed mud bricks manufactured by a machine can also be used. These have a fine smooth finish, clear edges and walls using such bricks can take the load of a three-storeyed house.

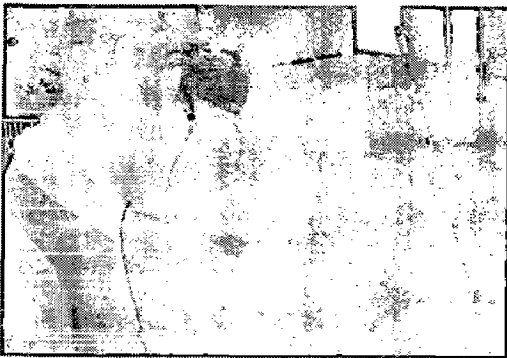

Figure 2.12 Building with sun dried bricks

Source: <http://www.powerhousemuseum.com/freeradicals/?p=106>

- **Wattle and daub methods:**

This is used particularly for meeting housing requirements in areas prone to cyclones or earthquakes. Wattle is used to form the structure of the house and mud is used to daub the walls. During the rains, the daub may be washed away but it is easily replaced. The wattle can withstand any earth tremors. (Fig. 2.13) However, mud walls are needed to be protected from the

rain. Traditionally, the walls were plastered every year with mud mixed with sand, twigs and cow dung. Laurie baker used stone wall on the base as a rain protection up to plinth level. (Fig. 2.14)

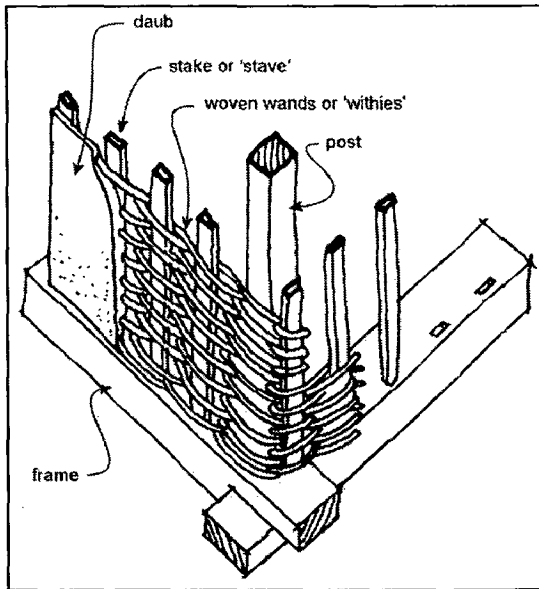
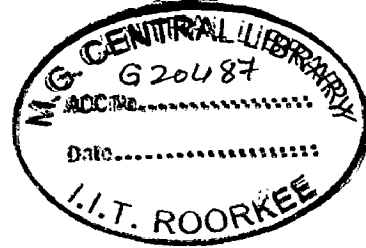

Figure 2.13 Structure of Wattle and Daub wall

Source: http://www.tonygraham.co.uk/house_repair/wattle_daub/WD-2.html

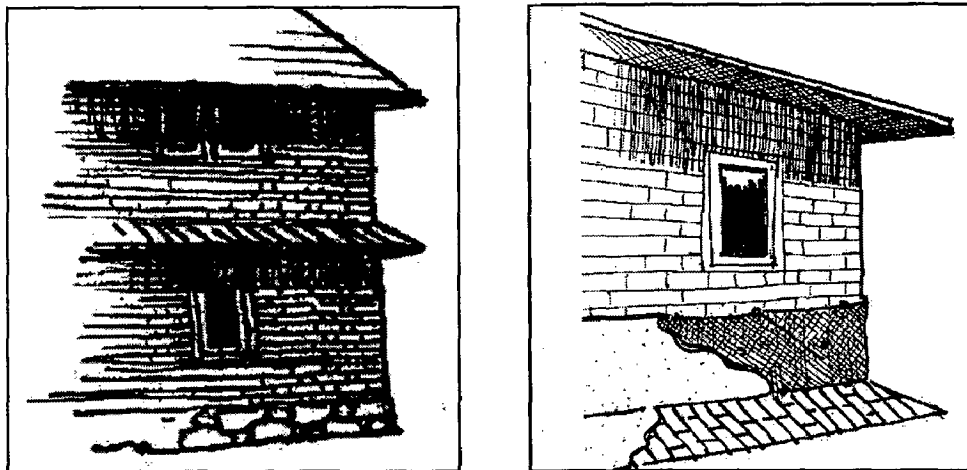

Figure 2.14 Methods of mud wall protection

Source: Baker Laurie (1986) Mud, COSTFORD

2.4.1.2 Stone construction

Stone is used in buildings after splitting it and breaking it up whereas traditionally, stone blocks were used. Splitting it and breaking it makes it weak and thus the walls made of stone tend to fall in disasters like earthquake. Traditionally, stone was used in the

foundations as well which was employed by Laurie Baker for many of his designs. Stone is also used for plinth protection and also it can resist termites. Laurie Baker provided some improved techniques to use stone as a building material.

- Bonding is very much important in wall construction. Traditionally, stone blocks were laid over each other in a manner that they interlock each other. (Fig. 2.15 & 2.16) The walls were rarely plastered. At times, the gaps were filled by thin mud plaster. In this scenario, in case of an earthquake, the stones were allowed to slide over each other and thus a stable wall was obtained. However, the 'modern' construction practices involve putting thick cement concrete with boulders which develop cracks under lateral forces of earthquake.

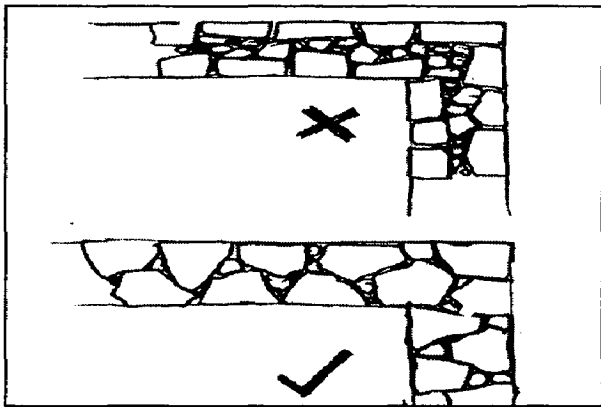

Figure 2.15 Proper bonding in Stone

Source: Baker Laurie (1986), Houses: How to reduce building cost, COSTFORD

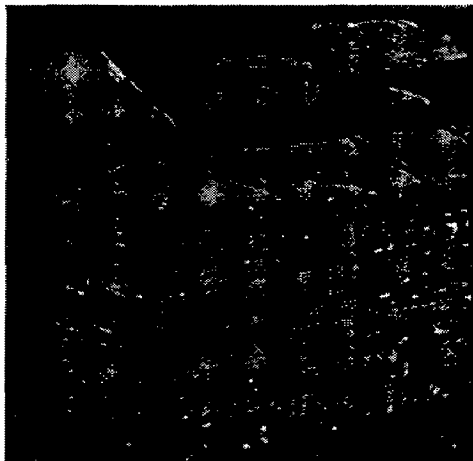

Figure 2.16 Stone blocks laid with proper bonding

Source: Baker Laurie (1992) Earthquake, COSTFORD

- The use of rounded stone found in the river bed was avoided since these provide a weak interlocking and are displaced in case of earthquakes. (Fig. 2.17) Instead these round stones are used in the pavements around the house.

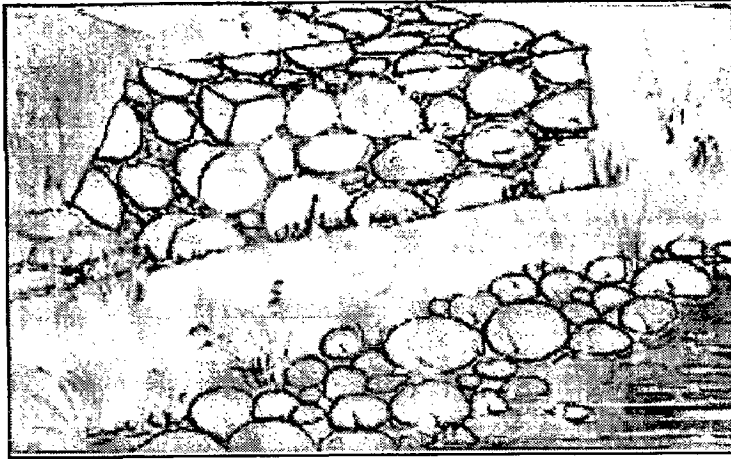

Figure 2.17 Round stones used in wall construction

Source: Baker Laurie (1992) Earthquake, COSTFORD

- The use of smaller stones should be avoided. In 'modern' houses, the smaller stones are used in the gaps which do not provide any bonding. Thus Laurie employed the use of stone blocks in wall construction. The small pieces of stone are put in a mould and then filled with concrete. (Fig. 2.18) This produces a stable building block which can be used in walls and bonded with plaster.

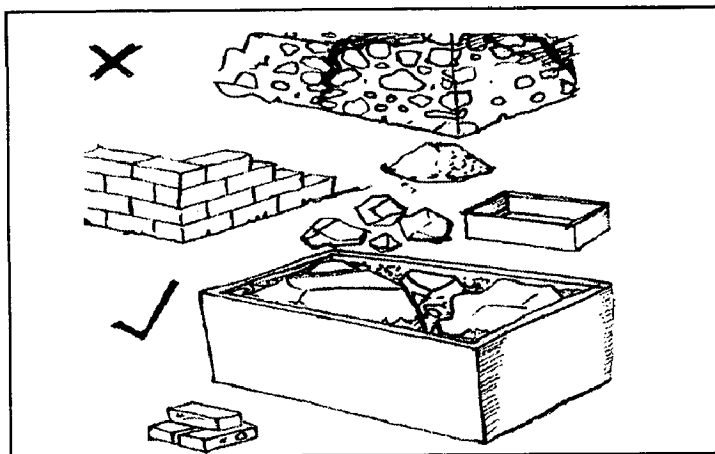

Figure 2.18 Small stones used to produce blocks

Source: Baker Laurie (1986), Houses: How to reduce building cost, COSTFORD

2.4.1.3 Burnt bricks

Burnt bricks although not locally available at all sites but if the bricks are available at a short distance, then these may be used for construction. The reduced transportation reduces the embodied energy of the materials. These bricks can be employed more effectively to suit a certain climate. Laurie has advocated various techniques to reduce the cost of construction using brick as a construction material.

- **Rat-trap Bond**

The bricks are laid on edge in 1:6 cement mortar as shown in fig. 2.19. This arrangement reduces the cost of wall 25% as with conventional English bond. No plastering of the outside face is required and the wall usually is quite aesthetically pleasing and the air gaps created within the wall help make the house thermally comfortable. In summer the temperature inside the house is usually at least 5 degrees lower than the outside ambient temperature and vice versa in winter. Electrical conduits can be accommodated in the hollows, which avoid chasing of walls as is normally practiced. It can be used for load bearing structures up to 2 storeys high.

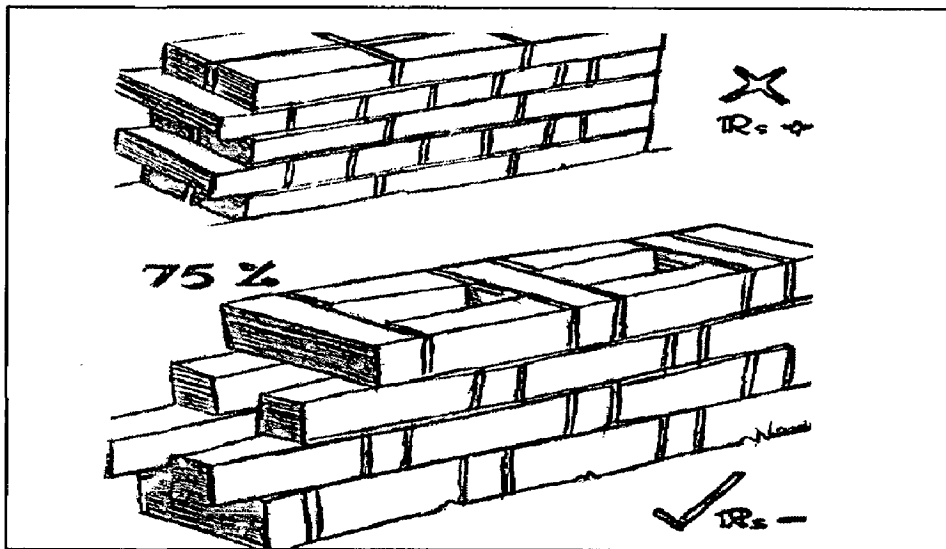

Figure 2.19 Rat- trap bond

Source: Baker Laurie (1986), Houses: How to reduce building cost, COSTFORD

- Bricks are often slightly irregular in length. So even if one side of a wall is smooth, the other side will be lumpy and irregular. Therefore plastering the wall is a must. Thus mortar can be used to fill over the sunken ends of the brick to produce a

special fair face on the second side of the wall. Plaster is not required and a pleasing pattern is achieved.(Fig. 2.20)

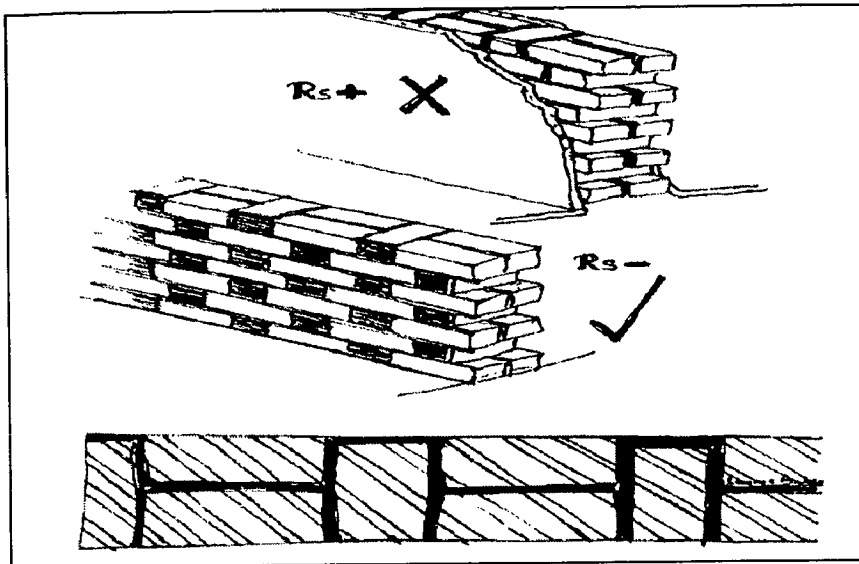

Figure 2.20 Minimising use of plastering

Source: Baker Laurie (1986), Houses: How to reduce building cost, COSTFORD

- A window has varied functions - to look out of, to let light inside a room, to let in fresh air, or to let out stale air, and so on. But are costlier than the simple brick or stone wall it replaces. In many of these situations a “JALI” or “honeycombed” wall is just as effective as shown in fig. 2.21. Jalis were used in the houses of Rajasthan where they were found effective to cut the sun and allow ventilation.

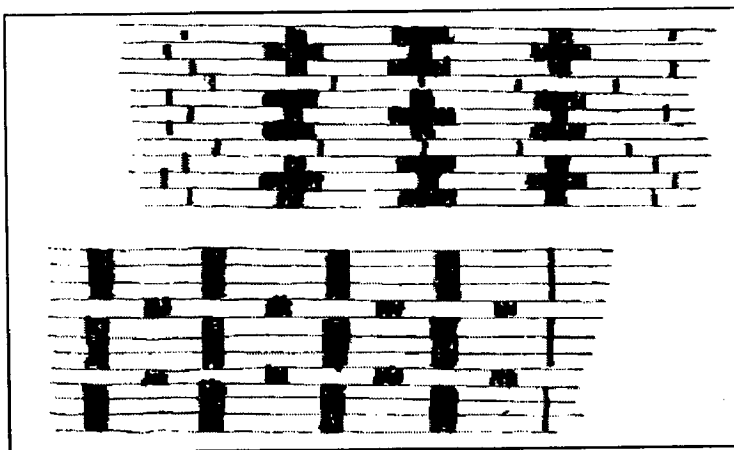

Figure 2.21 Use of Jali

Source: Baker Laurie (1986), Houses: How to reduce building cost, COSTFORD

2.4.1.4 Bamboo

Bamboo is strong and ductile. A fully grown bamboo can be used as reinforcement instead of the energy intensive steel bars. In areas where stone and brick are not available for foundations, bamboo can be used instead. The foundation trench is excavated, the soil moistened with a little, water and then replaced with layers of bamboo reinforcement inserted. (Fig. 2.22)

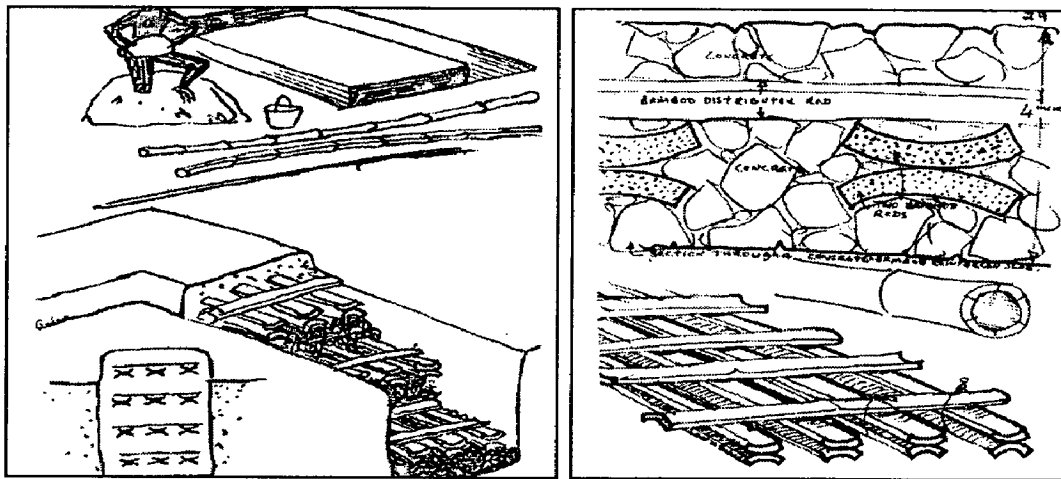

Figure 2.22 Use of bamboo as reinforcement in foundation and roof

Source: Baker Laurie (1986), Houses: How to reduce building cost, COSTFORD

2.4.2 APPLICATION OF TRADITIONAL CONSTRUCTION TECHNIQUES BY HASSAN FATHY

Ancient design methods and materials from the traditional architecture of Egypt adopted in modern construction by Hassan Fathy reaffirm the significance of traditional knowledge in present times. He believed that *architecture is for humans* [8] and pronounced through his designs that buildings are meant to be a response to the physical, psychological and cultural needs of the people. He discarded the international architectural style which remains same everywhere instead adopted the vernacular architecture as his design guideline. In his words, “*An architect is in a unique position to revive people's faith in their own culture. If, as an authoritative critic, he shows what is admirable in local forms, and even goes so far as to use them himself, then the people at once begin to look on their own products with pride.*” [9]

His design approach was not a blind adoption of the traditional materials and construction techniques. His adoption of the traditional construction forms and features of

Nubian Craftsmen of southern Egypt like the use of traditional domes, arches and vaults of mud brick which were also used for walls created his signature. The structures were cheap, cool in the summer and the walls were heat-retaining in winter. He evolved various prototypes of these vaults and used them in his designs in northern Egypt which suited the climatic conditions. A traditional arch used in his design is shown in fig. 2.23 below.

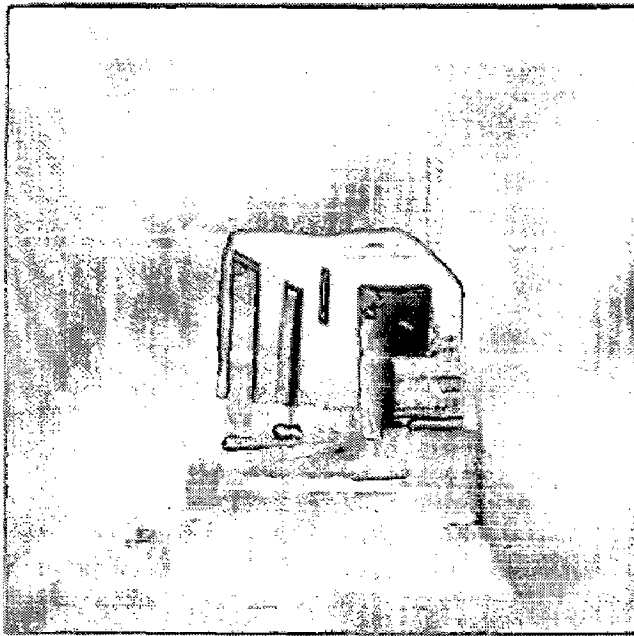

Figure 2.23 View of arched hall built with mud bricks.

Source: <http://www.touregypt.net/featurestories/newgourna.htm>

His introduction to self help housing was an initiative to encourage people into *participatory nature of the design process*. [8] He trained local inhabitants to make their own materials and build their own buildings. As an attempt to introduce individualism into his design, all houses that he built were a response to the individual's needs and response. He encouraged the peasants to make their own plans, build their own materials and erect themselves. He would study the use of a space for a few weeks before he designed it for the user. As he said in *Architecture for the Poor*, "*In Nature, no two men are alike. Even if they are twins and physically identical, they will differ in their dreams. The architecture of the house emerges from the dream; this is why in villages built by their inhabitants we will find no two houses identical. This variety grew naturally as men designed and built their many thousands of dwellings through the millennia. But when the architect is faced with the job of designing a thousand houses at one time, rather than*

dream for the thousand whom he must shelter, he designs one house and puts three zeros to its right, denying creativity to himself and humanity to man. As if he were a portraitist with a thousand commissions and painted only one picture and made nine hundred and ninety nine photocopies. But the architect has at his command the prosaic stuff of dreams. He can consider the family size, the wealth, the social status, the profession, the climate, and at last, the hopes and aspirations of those he shall house.”[10]

His design strategies were implemented first in the Gournia Village which was to be built of the rural poor who were to be evacuated from Luxor and rehabilitated in Gournia. The village, built from 1946-53, the architect's vision that the concrete-frame housing schemes imported from Europe for the rural poor would not work not only because they were too costly but did not accommodate to the cultural differences between Europe and the Middle East. Hassan Fathy built the low cost, locally and traditionally built structures at New Gournia as the alternative. Site Plan of the village is shown in the fig. 2.24 below.

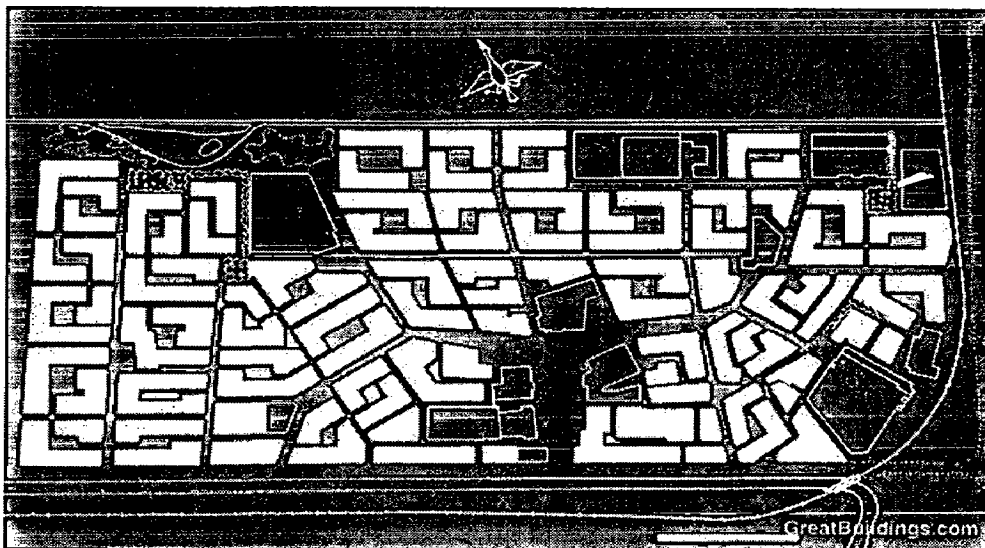

Figure 2.24 Site plan of Gournia

Source: http://www.greatbuildings.com/buildings/New_Gournia.html

The various sectors were all unique in their designs. Streets were laid out so as to ensure pockets for interactions between people. (Fig. 2.24) With his belief to ensure individuality, his designs vary from one house to another depending on the various configurations of family size and occupation. His designs depended on natural ventilation, orientation and local materials, traditional construction methods and energy-conservation techniques. Fathy incorporated the traditional dense brick walls and traditional courtyard forms to provide passive cooling. (Fig. 2.25) The bricks for the

village were made on site with the help of the villages and locals. He used traditional architectural elements of domes and vaults in the houses as well as the community facilities like the market hall etc. (fig. 2.26 & 2.27)

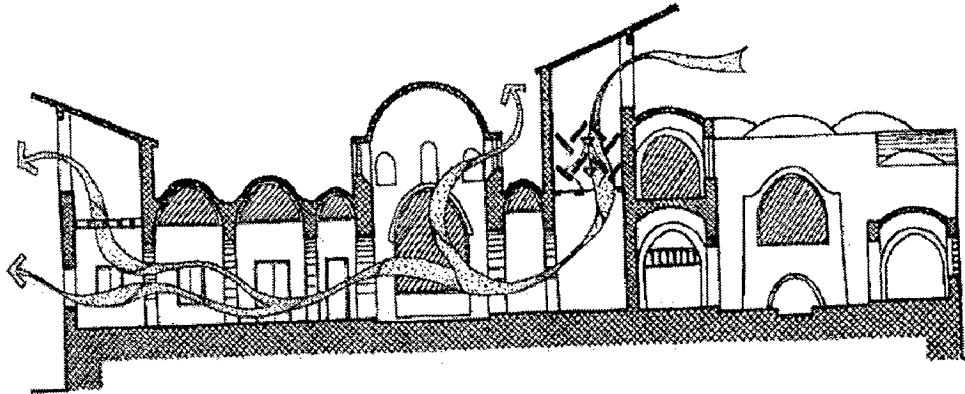

Figure 2.25 Movement of air through a typical traditional house

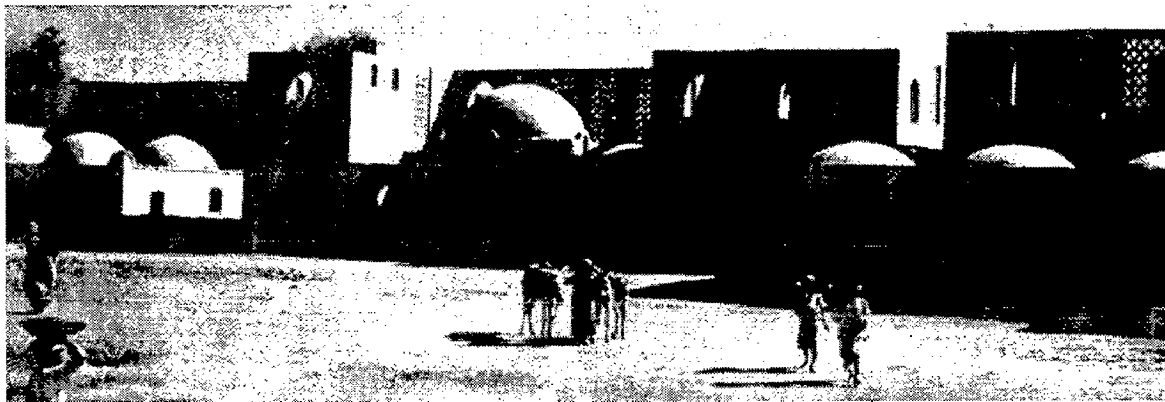

Figure 2.26 Gorna mall: Brilliant use of Vaults and domes

Source: Dabaieh Marwa, Traditions, Vernacular Architecture and Urban Form



Figure 2.27 View of the court and the on site brick making

Source: http://archnet.org/library/images/one-image.jsp?location_id=1547&image_id=16316

In his other designs for individual houses, his design statement remained the same. Use of these traditional ventilation and solar passive techniques made this type of construction more economical and sustainable. In his design of Suheymi house, he used a private, family courtyard on one side of the takhtabush screen which was planted and the formal, public courtyard on the other side was paved as shown in fig. 2.28. The resulting temperature differential created a flow of air from the cool, planted courtyard into the hotter paved courtyard, and the room above the courtyard that benefited most from this airflow was wonderfully cool, even on the hottest days.

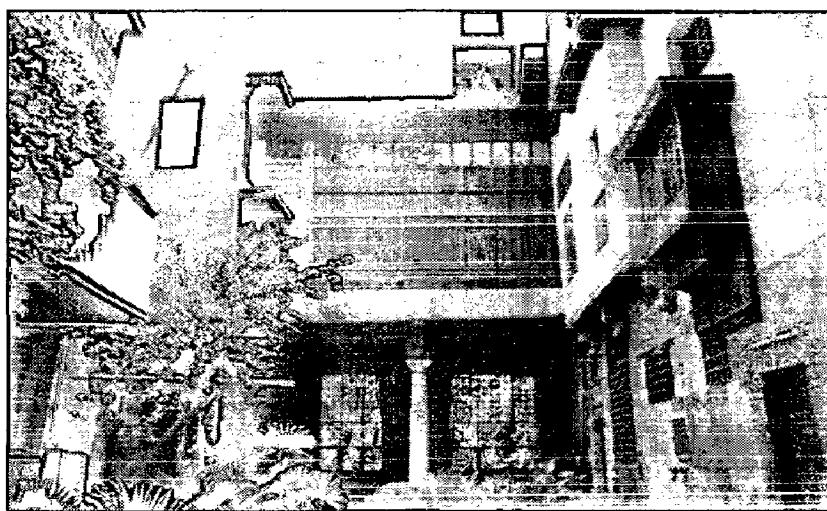

Figure 2.28 View of screen at Suheymi house

He was inspired by the elements of traditional architecture of Egypt. For example, the decorated wooden cupola inside the *qa'a*, the central airshaft in a house, at the top, was provided there to help the air rush up faster. Fathy looked at mashrabiyyah screens (typically Arabic element, projecting wooden screen) and found that they were not only decorative and good at soaking up the glare from the sun, but also that they had hydrometric properties, for the wood soaks up humidity, too. A typical Egyptian Mashrabiyyah screen is shown in fig. 2.29 below. Thus the spaces behind these projections could be used as living spaces which were more comfortable.

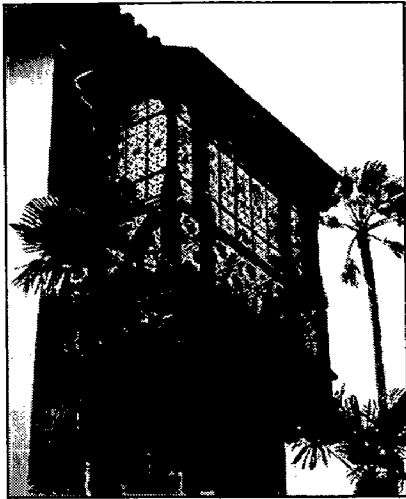

Figure 2.29 View of typical Mashrabiyyah

This sort of relationship between environmental aspects and the traditional elements in the houses were incorporate in his design language. He adopted the ingenious technique of constructing roofs in bricks without centering by constructing catenary vaults and domes which eliminated the need for scarce and expensive tensile materials such as reinforced concrete and timber centering. A section through a house in Gournavillage shows the extensive use of domes and vaults in the fig. 2.30 below. Another feature in his design was use of locally available materials like wood, stone, mud brick. The houses had thick mud walls for their thermal properties. The wood was used in floors and roof as in traditional houses.

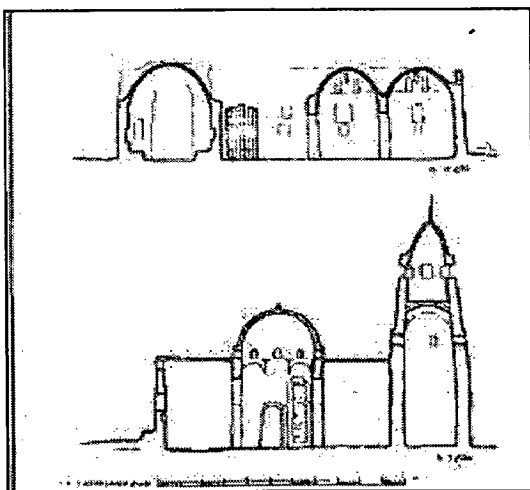

Figure 2.30 Section across house and across courtyards

2.4.3 APPLICATION OF TRADITIONAL CONSTRUCTION TECHNIQUE BY CENTRE FOR VERNACULAR ARCHITECTURE

Architectural practices promote the use of locally available materials, traditional building techniques, culturally and climatically relevant building design in the designs by R.L.Kumar working in the field of various vernacular architectural projects in South India. A philosophy of sensitivity towards the environment and conservation of old practices is adopted in the various designs. These designs are not just climatically applicable, but are also culturally relevant and cost-effective. The designs are connected with nature by exposed stone and brick work. Construction techniques adopted by CVA are inspired by the techniques used by Laurie Baker in his designs like exposed brickwork, brick jali, brick arches, filler slabs etc. but they have adopted these techniques for large commercial and institutional projects. The materials adopted are native to these areas including laterite, stone, mud, etc. Foundations are laid in random rubble masonry and sand. (Fig. 2.31)



Figure 2.31 Traditional materials used in resort

The walls are built with the random rubble masonry and brickwork provided with overlapping joints on edge to give the walls extra strength. Stone wall is erected up to the first floor. Filler slab, brick dome, mangalore tiles, thatch roof and mud-packed roofs are adopted for ceilings. However, floors are made of unpolished shahbad or mud packed floor varying with the use of the space. Knowledge of the skilled craftsmen is used for erecting traditional thatch roofs etc.

2.5 SUMMARY

Traditional construction techniques are derived from the locally available materials. Climatic, geographical, social, cultural and environmental factors affect the use of a construction technique in a region. Traditional techniques in warmer and colder climates involve use of materials which provide greater time lag to avoid exchange of energy between outside and inside. Resistance to natural hazards is another criterion for the choice of technique employed in the region. Various traditional materials like mud bricks, rammed earth, stone, wood and bricks have been successfully used in modern construction reinstating the significance of traditional materials and construction techniques in the modern context for a cost effective energy efficient, and sustainable construction. Traditional architecture in hills is peculiar due to geographical constraints. Traditional construction techniques specific to the hilly regions of Uttarakhand, Kashmir, Assam and Himachal are discussed in detail in the next chapter.

CHAPTER 3: TRADITIONAL TECHNIQUES OF HILLS

3.1 INTRODUCTION

Traditional construction techniques are a response to the local climate, geography and materials. The traditional hill architecture is peculiar due to its difficult terrain and climatic constraints. The geomorphologic characteristics of hills render challenge in the site selection in hills and the difficult access to these regions has allowed the people to understand their surroundings and develop techniques which would adhere to the local conditions. Due to similarity in the climatic conditions in these regions, there is a similarity in the construction material use in the traditional construction across the world. The houses are built as small hamlets spread over an area since the topography of these hills does not allow large areas for construction. This forces the local people to build houses that meet all their needs and that are self-sufficient. The houses are generally built on the steeper slopes while the milder slopes are used as agricultural land. For the purpose of this study, traditional construction techniques of different hilly regions with similar climate as the study area that is Uttarakhand, Kashmir, Assam and Himachal Pradesh are discussed so as to identify the various factors responsible for the choice of material and technique in the hilly regions.

3.2 TRADITIONAL CONSTRUCTION TECHNIQUES IN UTTARANCHAL

The state of Uttarakhand lies in the south slope of Himalayas. Major part of this state is mountainous lying in the Greater Himalayan range with snow covered peaks. The climatic condition of Uttarakhand varies greatly due to variation in altitude and proximity towards Himalayan ranges. The hilly regions have characteristic alpine conditions with cold winters with snowfall, good rainfall in the monsoon and mild summers.

The traditional buildings in the Garhwal region are identified as *Koti Banal* architecture which are not only climate responsive but are also earthquake resistant structures proven by their performance in various earthquakes. Traditionally, these multi-storeyed structures are called Chaukhat (for four storeyed) and Panchapura (for five storeyed) structures are built with wood and stone.[11] These types of houses have a simple rectangular plan with one single room on each floor with a low roof towards the

rear with a small ante-room used for storing wood. The upper floors have external balcony. (Fig. 3.1) The kitchen is generally located in the top floor of the house.

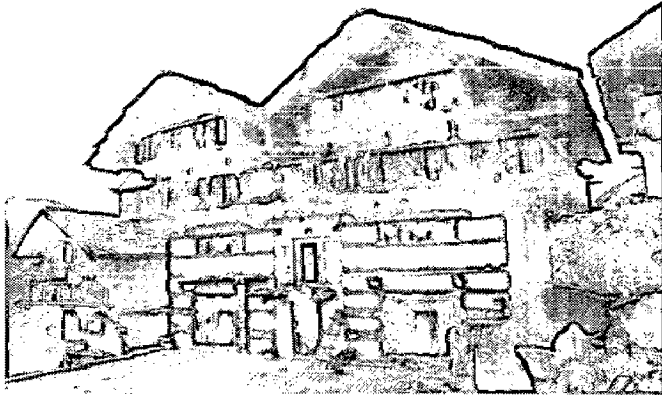

Figure 3.1 A typical multi-storeyed house in Uttarakhand

Source: <http://www.emeraldinsight.com/journals.htm?Articleid=1798742&show=html>

The houses in the area are mostly observed to be constructed on a raised and elaborate solid platform which provides stability to the structures. Locally available building material; long thick wooden logs, stones and slates are judiciously used for the construction of these structures. The height of these structures varies between 7 and 12 meters above the platform. The foundations are 2-3 ft deep laid using the interlocking technique (*Jor-tor*) in which stones are wielded with one flat stone and the space between is filled with fine rock pieces. The walls of these multi-storeyed structures are raised by placing double wooden logs horizontally on the edge of the two parallel sides of the platform. The other two walls are raised with well-dressed flat stones and laid with a layer of 30 cm high wooden logs and stone on the other walls thus alternating the layers of wood and stone. (Fig. 3.2) The thickness of the walls is determined by the width of the logs (70 cm). [11]

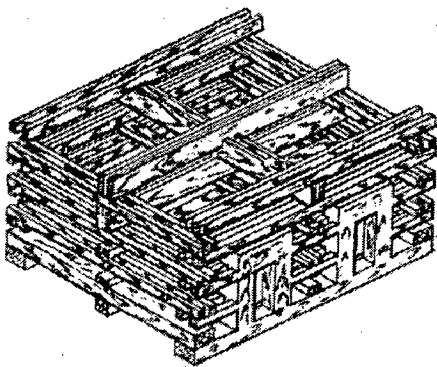

Figure 3.2 Bonding in wooden members in traditional construction

Source: <http://www.emeraldinsight.com/journals.htm?Articleid=1798742&show=html>

A typical house in lower ranges is double storeyed with the very low rooms on the ground floor, which are usually 1.8 mt. The height of the upper storey is generally 2.1 mt. A mud or stone staircase or a wooden ladder leads to the upper storey, the roof being of wood. The roof is usually a sloping structure of timber covered with Patals (quartzite slabs). [12] Generally the upper storey has a verandah in front of the upper rooms which has intricately carved wood work. (Fig. 3.3) Wood on upper storey makes the structure light in case of a disaster.



Figure 3.3 Stone houses in Kumauni village

Source: <http://www.thegoodwebguide.co.uk/?PAGEID=012144>

While in the lower ranges, houses are built either as random rubble masonry with undressed stones or mud block construction. The wall is made of two separate sections, outer and inner widths. The space between two widths is filled with stone rubble. This type of wall has a tendency to split and buckle into two separate widths due to lack of interlocking. Another practice includes masonry work with slate wafers. The dressed stones and slate wafers are stacked lightly with very little or no mud mortar in between. The masonry wall with slate wafers performs better than random rubble masonry under lateral loads.

3.3 TRADITIONAL CONSTRUCTION TECHNIQUES IN KASHMIR

State of Jammu and Kashmir lies in north western part of Indian sub-continent and is the northern most part of India. Kashmir valley lies between the Himalayas and Pir Panjal range. The climate is fairly warm in summers but cold in winters with snowfall

very common. The rural and urban areas show a marked variation in the type of construction.

The traditional construction in rural Kashmir is dictated by the cold climate and easy access to good soil for brick-making, and availability of timber. As a result, walls are made mainly out of timber and bricks, baked or unbaked with mud or cement mortar with or without plaster or unbaked brick with baked brick veneer masonry with mud mortar, with or without plaster. Internal walls are made with unbaked brick with mud mortar and mud plaster. A characteristic type of construction in the region is Dhajji -dewari timber framed constructions with infill of baked brick in cement mortar or unbaked brick masonry in mud mortar, both 4" thick with timber frame as shown in fig. 3.4. Many structures which are typically single- and double-storey have Dhajji walls in the upper storey and the gables. Planks or shingles of hardwood like Deodar were used as the main roofing materials. [13]



Figure 3.4 Traditional house with Dhajji dewari construction

Source: Desai Rajendra, Desai Rupal (2007) Manual for Restoration and Retrofitting of Rural Structures in Kashmir, UNESCO & UNDP

The urban areas of the Valley have distinct high density development. Thus most of the houses are three to four-storey structures. The two most common walling systems observed are Dhajji type, with timber frame and infill consisting of baked or unbaked bricks, and Taaq type, consists of load bearing masonry piers and infill walls, with wood “runners” at each floor level and at lintel embedded into both sides of masonry walls. These runners are tied across the wall and also at the corners as shown in the corner detail in fig 3.5.



Figure 3.5 Traditional house with Taq construction and corner detail

Source: Desai Rajendra, Desai Rupal (2007) Manual for Restoration and Retrofitting of Rural Structures in Kashmir, UNESCO & UNDP

http://portal.unesco.org/geography/fr/files/7325/11811189505Taq_Poster.jpg/Taq%2BPoster.jpg

3.4 TRADITIONAL CONSTRUCTION TECHNIQUES IN ASSAM

Assam is the north eastern state with elevation varying from 300-400 mt high. The mountainous terrain in the state created by the Brahmaputra and its tributaries creates a difficult terrain for construction. The region receives very high rainfall and the winters are cool. The region is also prone to natural disasters like earthquake, floods and landslides. The traditional construction has been evolved to withstand these disasters along with creating comfortable conditions for the inhabitants.

A typical traditional Assam type house is of two stories house built symmetrical on both sides with open spaces provided in front (chotal) and back side (bari) of the house which facilitates in ventilation in the monsoons. The house rests on a one 60 cm high plinth made with one brick thick wall. The structure of the house is made with wooden frame with vertical posts nailed into the plinth. Continuous horizontal members are provided at plinth, sill, lintel and eaves. Smaller panels are created within the timber frame and ikara used to fill them. Each panel is fixed with horizontal bamboo rods and ikaras are cut into the size of the panel and laid vertically over bamboo rods (Fig. 3.6). After putting the ikara it is left to dry for few days. Then it is plastered with mud mortar on both sides in three layers of plaster done alternatively after drying of each coat.

Finished coat is of liquid mix of mud and cow dung. The roof is sloping made with GI sheets nailed into timber purlins.

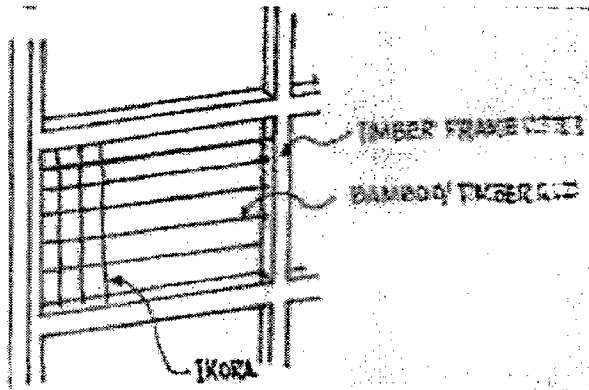

Figure 3.6 Laying Ikora within wooden panels

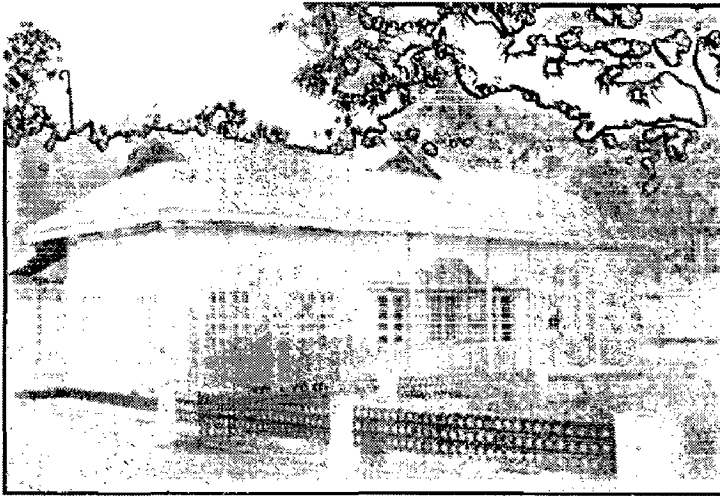

Figure 3.7 Traditional Assam type house

Source: Nath Rituraj,(2010) “Assam Type House – The Traditional Earthquake Resistant Construction Practice In Assam”, National Seminar on Disaster Mitigation in Housing in India.

3.5 TRADITIONAL CONSTRUCTION TECHNIQUES IN HIMACHAL PRADESH

The state of Himachal Pradesh nests in the western Himalayas covering with the elevation ranging from about 350 metres (1,148 ft) to 6,000 metres (19,685 ft) above the sea level. [15] There is great variation in the climatic conditions of Himachal due to extreme variation in elevation. The climate varies from hot and sub-humid tropical in the southern tracts to cold, alpine and glacial in the northern and eastern mountain ranges with more elevation. The state has areas like Dharamsala that receive very heavy rainfall,

as well as those like Lahaul and Spiti that are cold and almost rainless. Most parts experience very hot summers except in alpine zone which experience mild summer. Snowfall is common in alpine tracts (generally above 2,200 metres). These diverse climatic conditions have resulted into a large variety of construction practices across the state. The state of Himachal can be broadly classified into three regions depending upon their elevations (fig 3.8):

- The Trans- Himalayan region,
- The Higher Himalayan
- The Lower Himalayan region

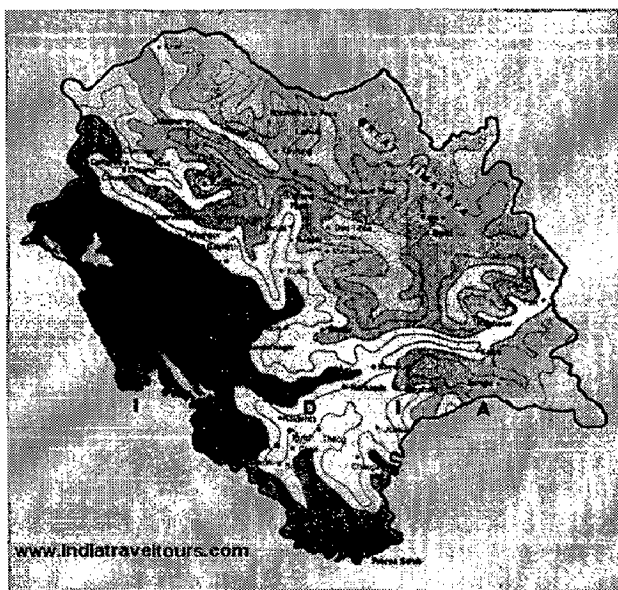

Figure 3.8 Physical map of Himachal Pradesh

Source: www.indiatravelstours.com

There is a variation in the architecture of different parts of the state. Even so, in a relatively small area several types of house are found which have different means of construction. The houses are planned in a compact manner on a square ground facing the south sun to allow the maximum sun penetration. Traditional houses are laid along the contours to avoid much disturbance to the topography. Stepped/ terraced planning is common in the areas if steep slope or very hard rock strata. The foundation is of several feet and is generally of stone. The stones are symmetrically arranged and are filled with a little the roofs are flat as well as sloping depending upon the precipitation in the region. Roofs are tiled with deep grey slates which are also native to the region.

The superstructure is also built with locally available materials, generally stone and wood or mud, with the wisdom of the local workmanship. The walls are generally left unplastered but at times surkhi (mixture of lime, brick powder, sand and jaggery, etc.) is used to plaster the outer walls. The climatic conditions of the region determine the type of construction which may use one of these materials or at times a combination of two or more. Depending on the materials used and the type of construction, traditional techniques are categorised into five categories Kath-kunni, Dhajji construction, wooden construction, Stone construction and Mud construction.

3.5.1 KATH-KUNNI CONSTRUCTION

This type of construction is mainly found in the higher ranges of Kinnaur and Kullu districts of Himachal. The walls are constructed of alternate layers of wood and stone. The wood battens 4"-6" thick extend beyond the wall length and interlock with the wood on perpendicular wall. The wooden planks are interlocked by lap joint. (Fig. 3.9) Floors are made of wood not more than 7-8 ft high for better insulation. The upper floors project out of the stone wall with wooden balconies creating a sun space for sitting. Thus maximizes the heat gain. This type of construction is earthquake resistant as the wooden battens form a framework which is well bonded and gives ductility to the otherwise rigid stone wall.

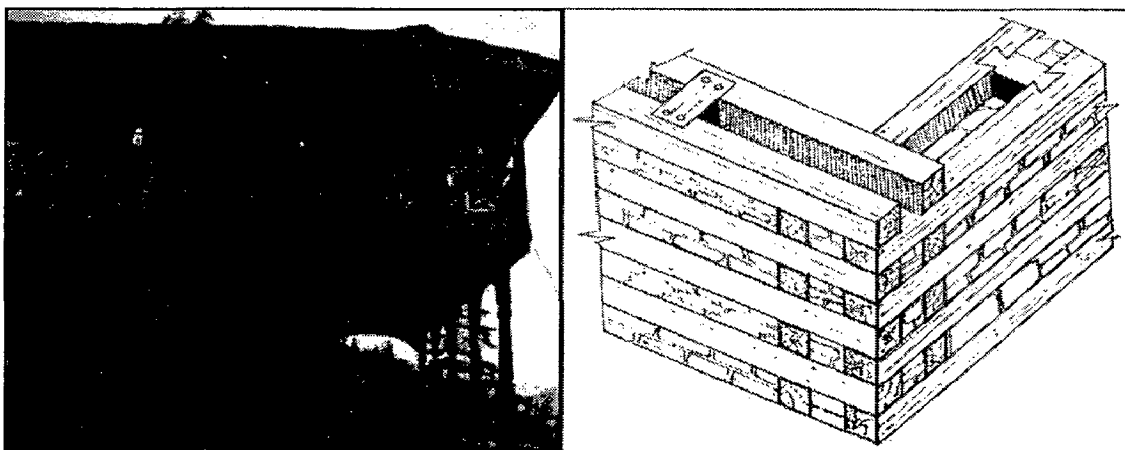

Figure 3.9 Typical house in Kullu and detail of alternate layers of wood and stone

3.5.2 DHAJJI-WALL CONSTRUCTION

Dhajji-Dewari is derived from Persian meaning "patch quilt wall." Such construction is common in the Kashmir valley and the hills of Shimla. It is characterised by walls of wooden bracing with in-fills of large mud bricks or stone closely packaged. The large timber members rest along the load bearing masonry walls with the floor beams and the runners for the cross walls lapping over them. (Fig. 3.10) The wood serves to tie the walls of the structure together with the floors. It is lighter in weight, allowing for its use on walls that are cantilevered over the street. The surface is plastered with a coat of mud and lime at some places. This type of construction is economical and structurally stable. The fame of wood distributes the lateral loads in case of an earthquake.

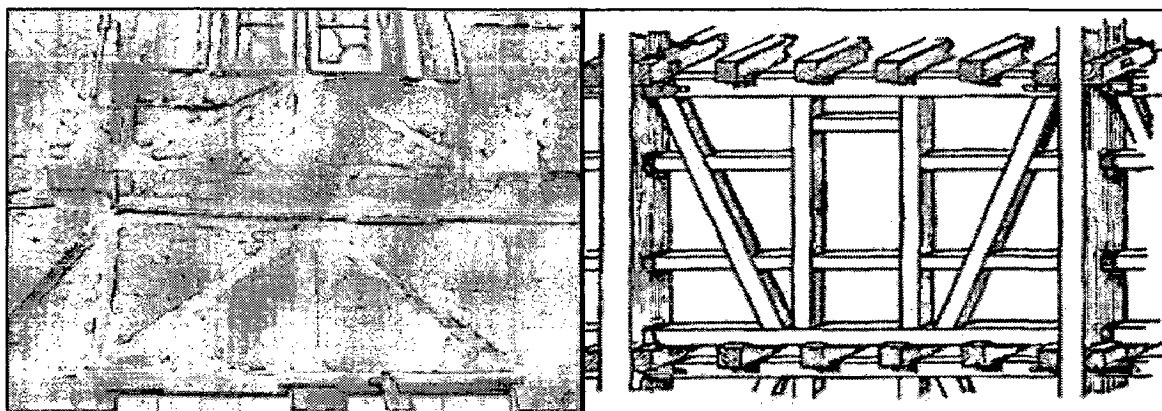

Figure 3.10 Wooden bracing in Dhajji wall system and system of wooden framing

Source: Desai Rajendra, Desai Rupal (2007) Manual for Restoration and Retrofitting of Rural Structures in Kashmir, UNESCO & UNDP

3.5.3 WOODEN CONSTRUCTION

Wooden construction is very common in hilly areas for easy availability of construction wood and its thermal properties provide relief from the cool winters. In Himachal this construction is common in most of the areas except cold and dry Lahaul-Spiti, in combination with other techniques at times. Houses are built 2-3 storeys high where the vertical wooden posts are meant to carry the load. Horizontal members are placed at different levels with an in-fill of wooden battens. The upper floors are cantilevered thus providing living space all around. (Fig 3.11) In some cases, the ground floor is built in stone masonry with the upper floor of wood.

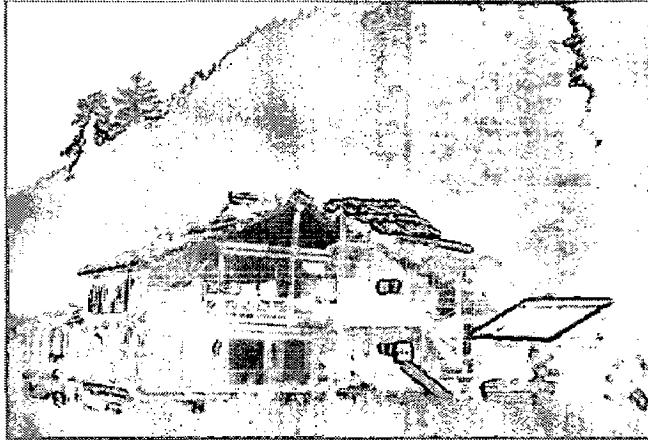

Figure 3.11 Typical house with wood construction

Source: <http://www.skyscrapercity.com/showthread.php?t=638698&page=34>

3.5.4 DRY STONE CONSTRUCTION

Dry stone construction is common in Kangra region where slate is in abundance. However, this type of construction is also common in Kinnaur district where good quality stone can be quarried. Different sized stones are placed over each other and compacted without the mortar. (Fig. 3.12) Through stones are used at regular intervals. A stronger bond is achieved by interlocking the stone rather than adding smaller stones in gaps. Interior surface may be mud plastered. The stone masonry structural walls take main lateral and gravity load. The walls uniformly distribute the load in both orthogonal directions.

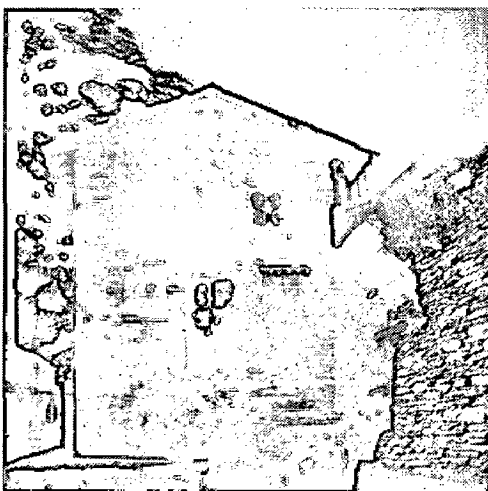

Figure 3.12 Typical construction with dry rubble masonry using dressed stones

Source: <http://www.pbase.com/digitalfestival/image/48068864>

3.5.5 MUD CONSTRUCTION

Mud construction is prevalent in Himachal in two types, rammed earth construction and sun dried mud construction. Rammed earth construction is common in the areas where construction materials like stone and wood like the cold desert of Lahaul-Spiti. Thick walls upto 2 feet wide are built with by pouring wet mud mortar and ramming it to make it compact before pouring another layer. (Fig. 3.13) Monolithic walls thus constructed keep the interiors cold in the chilling winters but earthquake resistance of this construction varies with the form of and the building the type of loading on the walls. Sun dried mud bricks are used in the Kangra region where good quality of mud is available from the river beds. The walls are made of sun dried bricks about 2-3 ft. thick plastered with mud phuska. (Fig. 3.13) These walls are susceptible to erosion due to rain thus the buildings are raised over stone or plastered to avoid it. The floors are made of wood plastered with mud enabling insulation. Thick flat mud roofs are used for insulation in Lahaul while in places with rainfall slate roofs are adopted. The roof is built over wooden frame resting on the mud walls.

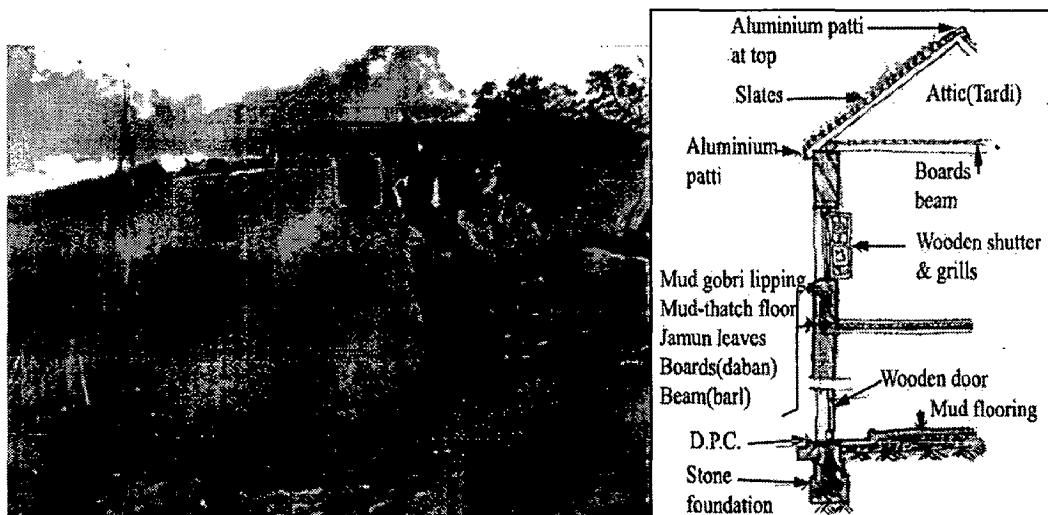

Figure 13 Mud houses in Lahaul and a typical section of mud wall

Source: <http://toptravelleads.com/tag/house-design/>

3.6 SUMMARY

Traditional construction techniques in hills are dictated by the climatic constraints and the availability of the materials. With a similarity in the climate and the choice of materials in these hilly regions, these construction techniques have evolved to be very

similar to each other. The most common building materials used is wood, stone and mud bricks. The choice of material used in different areas is dependent on its availability and structural properties. Any technique to be adopted in the hills should respond to the difficult terrain by the provision of strong foundation and stable walling techniques. Traditional construction techniques make use of the available resources to evolve a sustainable construction. Any new development should respect the site and adhere to the local needs. In order to assess the appropriateness of the traditional, modern and alternate techniques in the present context, an observational study is done for the three regions of Himachal which is discussed in the following chapters.

CHAPTER 4: PREVALENT TECHNIQUES IN TRANS HIMALAYAN REGION

4.1 INTRODUCTION

Trans Himalayan region of Himachal Pradesh is distinguished as a mountainous cold dessert with its high altitude above 3500 mt. traditional knowledge of building construction was employed for centuries in the region as an effort to counter the harsh climate and environmental hazards. It includes two valley regions, Lahaul valley and Spiti valley enclosed between lofty ranges. The region receives very little rain about 170 mm [14] due to the rain shadow effect thus climate is cold and dry with the cold nights all round the year but summer days are warm. Due to absence of moisture, sky is clear thus the radiations are harsh. This variation in the day and night temperature needs to be controlled for comfortable living conditions. The vegetation is scarce due to the harsh climatic conditions. Only hardy grass and shrubs grow upto 4750 mt with glacier lines usually found at 5,000 metres. [14] This chapter is dedicated to the study of the modern, traditional and alternate construction techniques prevalent in the trans- Himalayan region. An assessment of these techniques in the region is also done in terms of climatic response, material suitability and structural and seismic stability.

4.2 TRADITIONAL CONSTRUCTION TECHNIQUES IN TRANS HIMALAYAN REGION

Traditional construction technique prevalent in the region is mainly as mud construction since the region has scarce vegetation and the use of wood in the construction is to be very judicious. The wood is used only for structural members and grass, roots or willow bark are used on the roof as insulating material. Good building stone is also not easily available, thus the use of stone is limited strictly to the foundations and the plinth. Mud is used abundantly for walls, roofs, and floors. A typical house in the region is two stories high with the upper floor used for winters and the ground floor as the summer room. At times, the cattle are kept in the ground floor. (Fig. 4.1 & 4.2) The kitchen acts as the main living room in winters thus keeping the space heated with the smokeless burners.

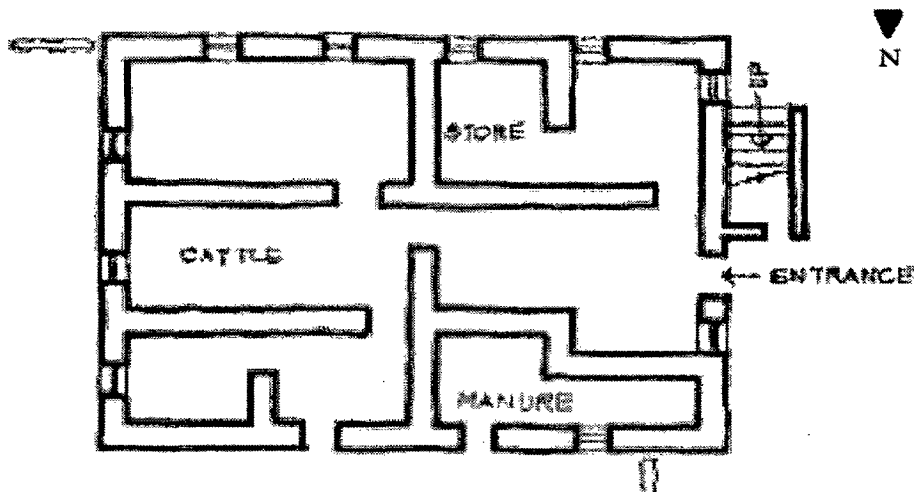

Figure 4.1 Typical house in Lahaul, Ground floor plan

Source: Gupta Vinod, Singh Ranjit, "ENERGY CONSERVATION IN TRADITIONAL BUILDINGSIN THE MOUNTAINS" School of Planning and Architecture, New Delhi

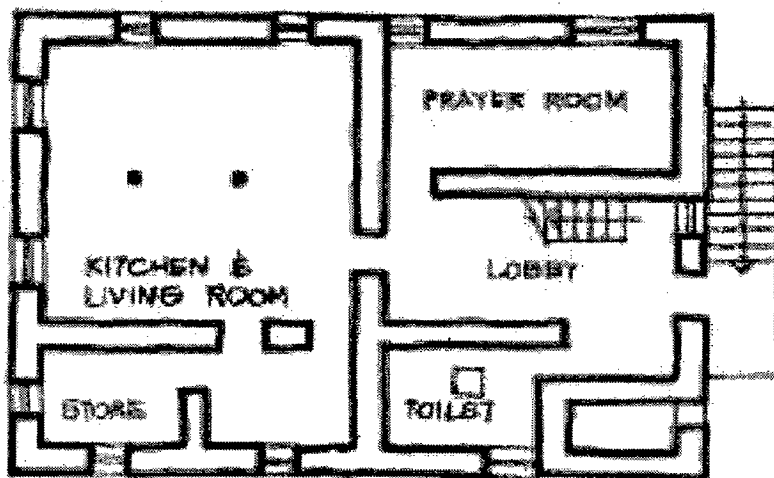

Figure 4.2 Typical house in Lahaul, Upper floor plan

Source: Gupta Vinod, Singh Ranjit, "ENERGY CONSERVATION IN TRADITIONAL BUILDINGSIN THE MOUNTAINS" School of Planning and Architecture, New Delhi

In the dry climate of the region, compacted earth walls are durable, and the mud-plastered surface requires little maintenance as there is hardly any rainfall. The structures generally rise to two or three storied high as seen in fig. 4.3 or more in case of monasteries. The walls of the house are slightly inclined and built with adobe bricks over a plinth and foundation of stone which stops the infiltration of moisture in the wall. (Fig. 4.4)



Figure 4.3 Typical house in trans-Himalayas

Source: <http://www.intoindia.com/adventures/trekking/himalayas-trek-with-homestays---spiti-valley/>

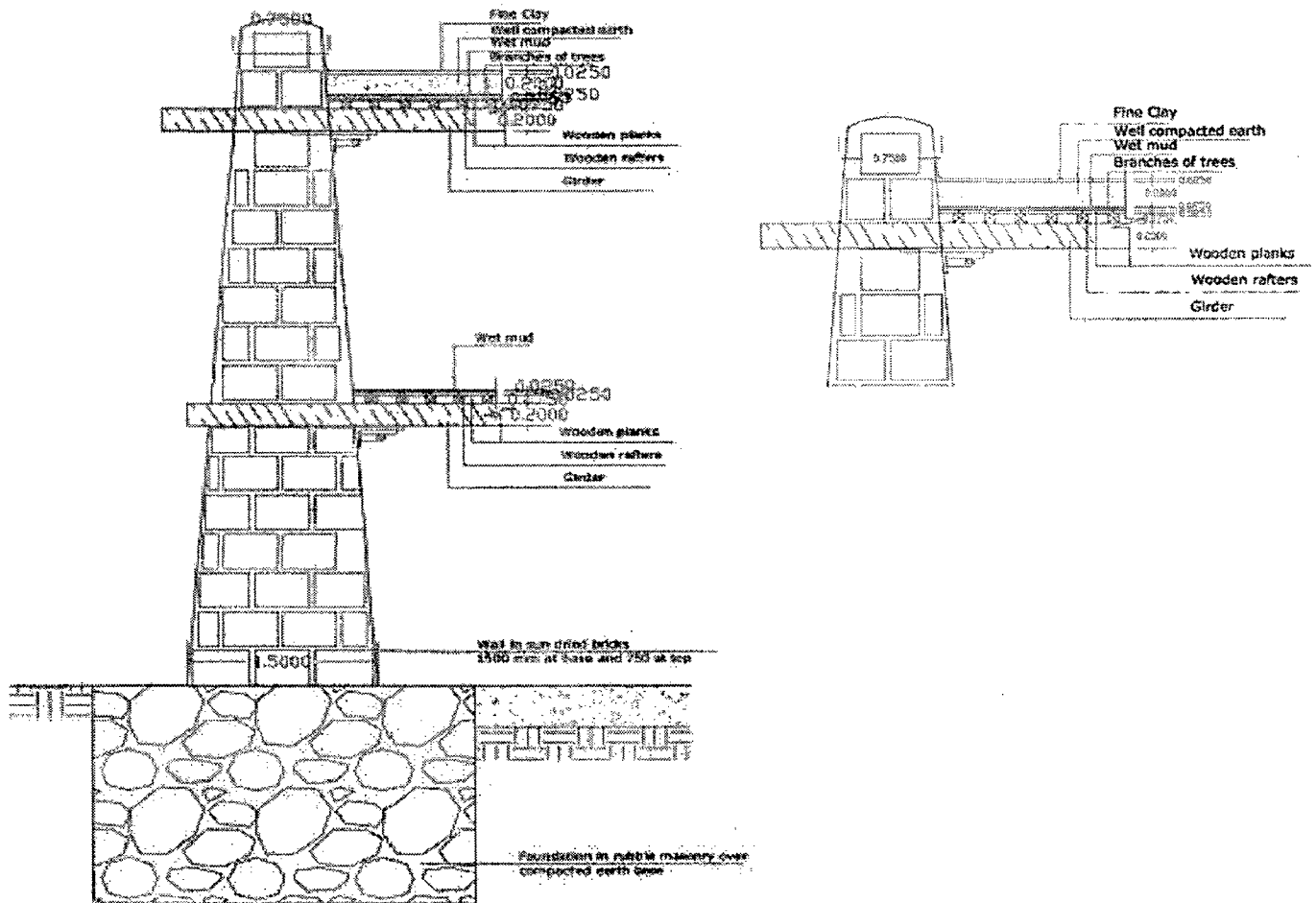

Figure 4.4 Section through the mud wall and details of roof

The openings are kept mainly towards the south direction to allow the sun inside and avoided in windward direction. Roof is flat and serves as storage for fodder and firewood which also provides an extra insulation in winters and constructed with earth supported on a framework of timber beams. Roof joists or the horizontal timbers run across between the tops of the walls and left exposed on the inside (fig. 4.5).

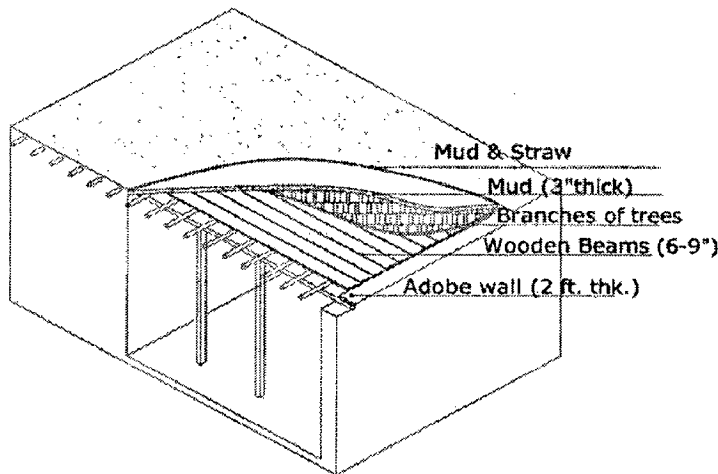

Figure 4.5 Roof detail

4.2.1. ANALYSIS OF TRADITIONAL CONSTRUCTION TECHNIQUES

Appropriateness of traditional construction techniques in the Trans Himalayan region is assessed under climatic response, material suitability and structural and seismic suitability for their significance in ensuring sustainability.

A. Climatic Response

The traditional construction techniques are meant to be suitable for the climatic conditions but with the global climatic variations, the mud wall construction has lost some of its appropriateness in the region.

- The regions of Lahaul and Spiti have received heavy rainfall in the past few years and thus the traditional houses have incurred some damage due to this. The mud coating on roofs has washed away and thus as a repair people resorted to further coating it with the mud which increased the dead load on the roof framework.
- The walls have become susceptible to moisture infiltration, thus making the walls weak.

- The openings are kept such that to avoid the cold winds in the winters which causes air tight conditions inside the house with the burners which causes unhealthy living conditions.
- Since traditionally, glass was not available in the region, wood was used in the shutters which were shut in winters causing dark conditions inside the room.
- The house becomes too warm in summers due to the increase in the global temperatures.

B. Material Suitability

- The use of mud is the sustainable solution for the region since the availability of both stone and wood is scarce. However, the mud walls are susceptible to damage from rains. The use of stabilised mud bricks can improve the performance of these structures.
- The mud walls are made very thick reducing the workable are of the house. There is a need to use materials which can provide insulation in thinner walls.

C. Structural and Seismic Stability

The structural framework of the traditional mud construction is mainly based on the wooden columns and beams.

- For seismic resistance, walls are provided with a band of wooden member after the plinth (Fig. 4.6). But the huge mass of the wall makes it vulnerable in case of an earthquake.

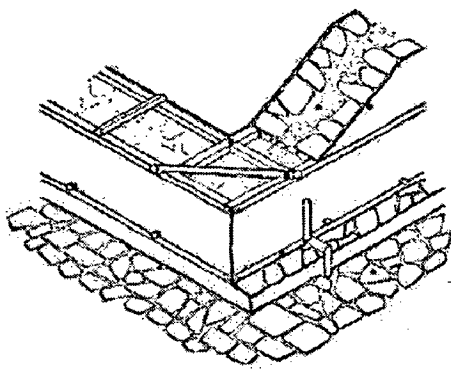

Figure 4.6 Detail of Earthquake band between plinth and wall

Source: Alexander André, Catanese Andreas (2007) *The Restoration of Tsas Soma Mosque, Leh, Ladakh, India: a report*, www.tibetheritagefund.org

- Foundations laid in dry rubble masonry are less vulnerable to seismic loads since they dissipate the energy in the form of frictional energy.
 - The roof is laid on the wooden framework supported on the wooden columns on point load which makes the columns more susceptible to compression failures.
 - The roof is supported directly on the load bearing mud wall without the use of base plate which makes the wall susceptible to breakdown in case of lateral loads.
- (Fig. 4.7)

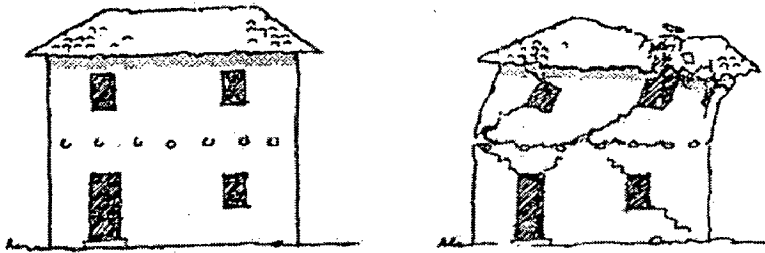

Figure 4.7 Earthquake failure in two storeyed mud walls

Source: Guidelines for earthquake resistant non- engineered construction (2007), National Information Centre for Earthquake Engineering

4.3 MODERN CONSTRUCTION TECHNIQUES IN TRANS- HIMALAYAN REGION

The modern houses in the region are built with brick, steel and cement. Walls are built as one brick thick resting on a brick masonry plinth and foundation with cement plaster on both sides. A framed structure of reinforced cement concrete is adopted with a roof of GI sheets. (Fig. 4.8)

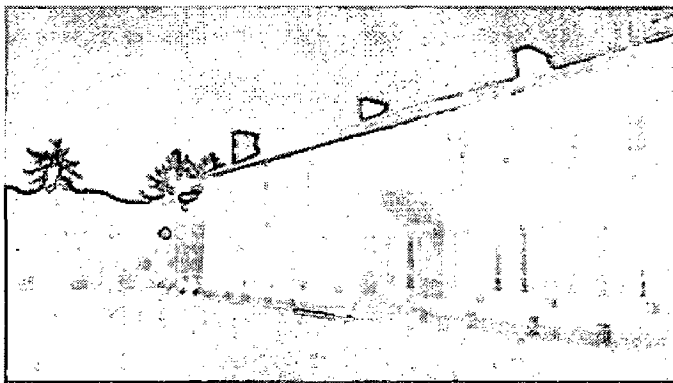

Figure 4.8 A modern building in Lahaul

Source: <http://www.team-bhp.com/forum/travelogues/47777-safari-dicor-2-2-vtt-tmt-grand-one-year-ownership-travelogue-kinnaur-spiti-lahaul.html>

4.3.1. ANALYSIS OF MODERN CONSTRUCTION TECHNIQUES

The sustainability of modern construction techniques for this region is analysed in terms of climatic response, material suitability and seismic suitability to assess its appropriateness.

A. Climatic Response

- Due to the severe climatic conditions in the region, brick masonry houses are found to be inadequate in the harsh winter conditions. Since the houses are not provided with any solar passive technique, they are found to be very cold in the winters. However, in case the cavity walls or trombe wall are used, performance of these structures improves adequately.
- The houses are provided with the same finishes as in the plains which do not comply with the climatic conditions of the region. There is a need to introduce good quality insulation materials in the construction process.
- The concrete floors are inadequate in providing the thermal insulation in the winters. The house may be warm in summer days but the nights are cold and uncomfortable.

B. Material Suitability

- It is a general perception by the residing people that the use of concrete and bricks is a cheaper alternative than the use of mud blocks which has caused a paradigm shift. However, these materials are needed to be transported from far away place which is neither cost efficient nor sustainable.
- The use of modern materials is preferred due to the lesser maintenance required than the mud brick walls.

C. Structural and Seismic Stability

- The houses built with modern construction techniques do not comply with the building codes and norms due to lack of technical know how and expertise in the area.

- The houses are not built as per the earthquake guidelines which make them vulnerable to earthquakes. Lack of provisions like plinth band and lintel band makes them unsafe.
- The houses built in the region, in absence of any check, have been found to be made with the materials of lesser grade and the construction joints in the structural members also tend to be faulty causing failure in case of any disaster.

4.4 ALTERNATE CONSTRUCTION TECHNIQUES IN TRANS- HIMALAYAN REGION

The building is constructed with modern materials but the construction techniques derived from the traditional architecture. It is designed with the reinforced concrete framed structure. The wall in the north is built as a cavity wall with 5 cm thick air gap sandwiched between 20 cm thick wall concrete block wall on the outside and 11.5 cm thick mud brick wall on the inside (Fig. 4.9). The air gap helps in providing a time lag and keeping the heat inside the building and does not let it travel.

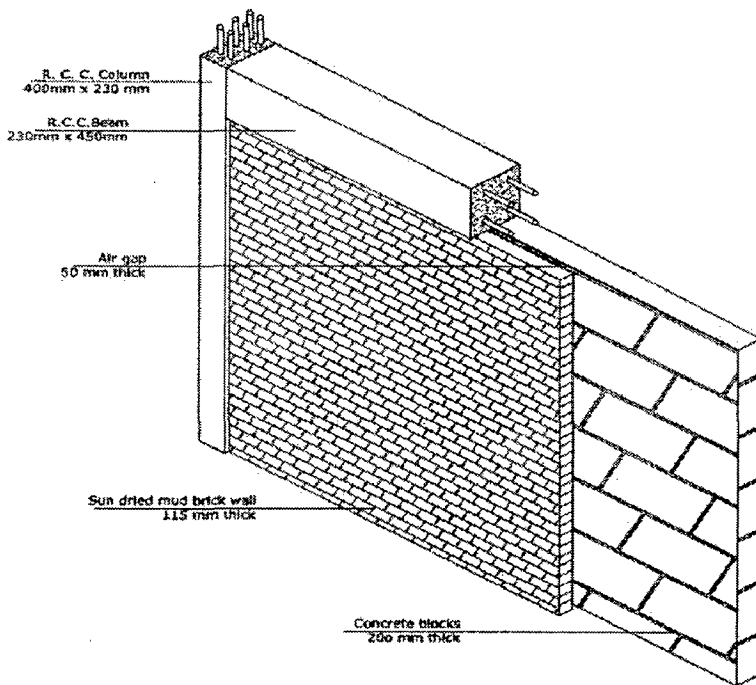

Figure 4.9 Wall in North direction

The walls on the west and east are constructed with an 8.5 cm wide layer of mud filling sandwiched between 20 cm thick concrete wall and 11.5 cm thick mud brick wall. (Fig. 4.9) internal walls are made of 23 cm thick mud brick walls. Mud plastering is done

on internal surfaces of all walls and wooden panelling inside up to 100 cm to safeguard from moisture.

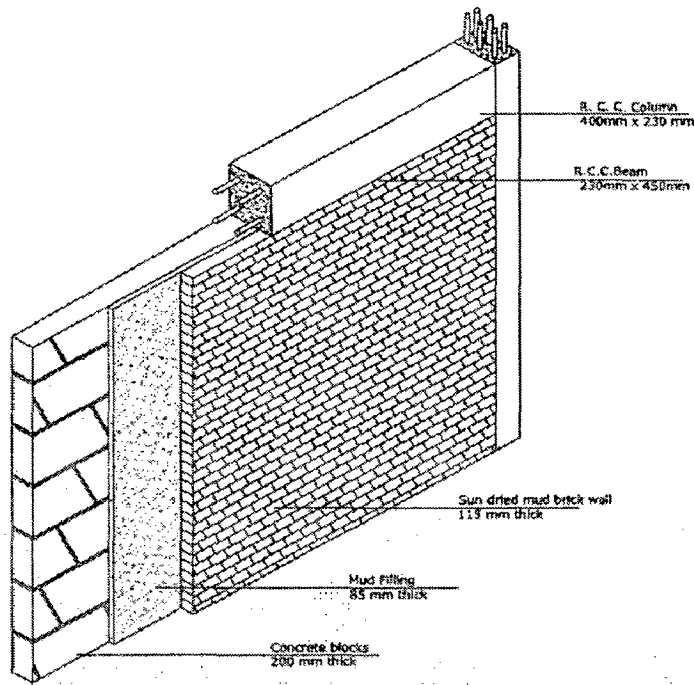

Figure 4.10 walls in east and west

The southern side of the building is most effective in catching the sun rays so to enable maximum sun, the building is provided with maximum fenestration on this side with double glass window panes to allow the heat to come inside but not allow it to escape. (Fig. 4.8) The windows are designed with maximum fixed panes and few open able windows to make the room airtight

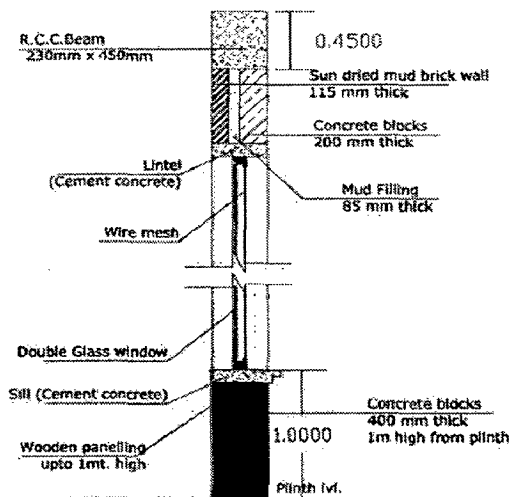

Figure 4.11 Window detail on South

4.4.1. ANALYSIS OF ALTERNATE CONSTRUCTION TECHNIQUES

An appraisal of alternate construction techniques in terms of climatic response, material suitability and structural and seismic suitability is done to assess its suitability in the region.

A. Climatic Response

- The walls are well suited for the climatic conditions of the region. The cold from the northern side is blocked by the use of cavity wall which provides a barrier to the cold.
- The sun is allowed into the rooms through large windows on the southern side but use of fixed windows does not allow proper ventilation.
- The facing of concrete blocks makes the building more durable against water splashes. The base of concrete blocks up to 1 m above the plinth provides good protection against moisture.
- The mud brick wall on the inside provides insulation and retains the heat inside.

B. Material Suitability

- The materials used are not locally available and are to be imported but the use of concrete blocks reduces the waste generation and the structural properties of the blocks are uniform which makes it appropriate for the region.
- Technical knowledge for manufacturing and building with concrete blocks is still new and the masons need to be trained to make it an efficient solution.

C. Structural and Seismic Stability

- The junctions formed between the concrete blocks mud brick with the R.C.C. columns needs to be treated with precision to ensure proper bond at the corners.
- There is no provision for seismic bands in the walls making it earthquake prone.

4.5 SUMMARY

Trans- Himalayan region is a witness to traditional, modern and alternate construction techniques. Traditional construction techniques which are climate responsive are not appropriate in the present times in their original form. On the other hand, modern construction techniques have not been adapted for the harsh climates of the region. The material availability in the region is a major criterion for the choice of technique due to the difficult terrain and access. Alternate construction however, has combined the traditional and modern knowledge to evolve construction technique which can be adopted for its climatic and material suitability. Prevalent techniques of higher Himalayan region are discussed in the following chapter.

CHAPTER 5: PREVALENT TECHNIQUES IN HIGHER HIMALAYAN REGION

5.1 INTRODUCTION

Higher Himalayan region is identified with steep green slopes and snow clad peaks. It consists of regions of Kinnaur, Kullu, higher ranges of Shimla, Chamba and Kangra. The elevation in the region varies between 1250-3500 mt. The geography of the region varies from steep slopes to the valleys along the rivers of Beas, Satluj and Ravi. The climate of the region varies from chilly winters with snowfall to warm summers. This region also receives monsoon in the months of July- August. The prevalent techniques in these regions were studied under traditional, modern and alternate techniques. This chapter is dedicated to the study of the modern, traditional and alternate construction techniques prevalent in the higher Himalayan region. An assessment of these techniques in the region is also done in terms of climatic response, material suitability and structural and seismic stability.

5.2 TRADITIONAL CONSTRUCTION TECHNIQUES IN HIGHER HIMALAYAN REGION

Traditional construction in the higher region is devised to counteract the cold climate of the region. Traditional construction practices in the region are dictated by the availability of the material. The region comprises of large extent of forest area and easily available stone both in the higher ranges and the valley regions. The traditional construction in the region includes same materials like wood and stone but techniques employed in constructing a building vary. The study of traditional construction techniques is thus divided in four areas, namely, Kinnaur, Shimla, Manali and Chamba.

5.2.1. TRADITIONAL CONSTRUCTION TECHNIQUES IN KINNAUR

The region of Kinnaur is a mountainous area with altitude ranging in from 2,320 to 6,816 metres. Most of Kinnaur experiences a temperate climate due to its high elevation, with long winters from October to May, and short summers from June to September. The lower parts of the Sutlej Valley and the Baspa Valley receive monsoon rains. [16] The higher ranges have sparse vegetation randomly hardy grass, however the middle and lower region, ranging from 3500 and below grows number of trees which are used as firewood, cattle fodder and also in the construction of buildings. Planning of a house is done for protection from cold and the cold winds. The location of the house is selected

such that and there is some protection from the cold winds. Typical house is built with a compact floor plan with minimum openings with ground floor for keeping cattle and as storage area shown in fig. 5.1. In winters, upper floor is used for living with the kitchen to take advantage of the heat.



Figure 5.1 Traditional house in Kinnaur with Kath Kunni construction

The house is built over 1m high plinth of stone and stone foundation to protect from the heavy snowfall. The walls are about 2 ft. thick laid over a platform in alternate layers of wood with dressed stone which is called Kath-Kunni construction. Wooden logs on the perpendicular walls are joined at the corner though nailing wooden pegs and bonding the walls forming the structure of the building. (Fig. 5.2) The structure is further reinforced with the help of wooden beams fixed alternately that run from the middle of the walls of one side to the other, intersecting at the centre. (Fig. 5.3)

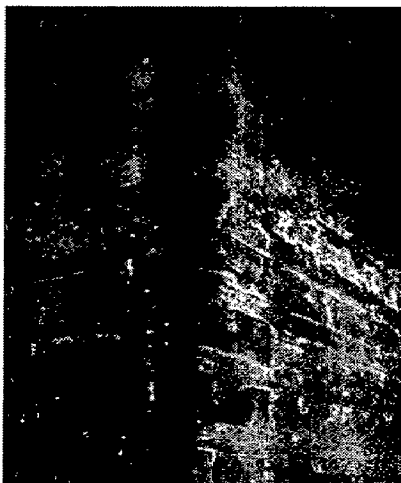

Figure 5.2 Typical corner detail in Kath Kunni construction

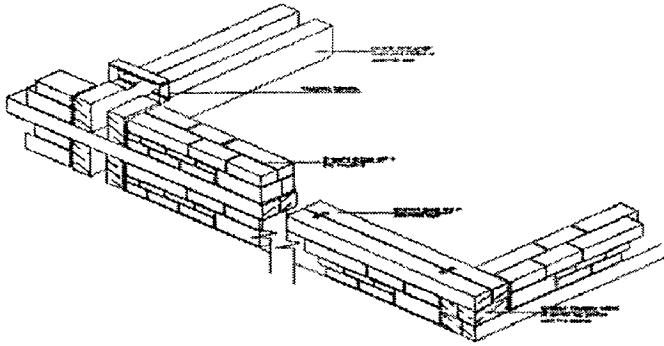

Figure 5.3 Laying wall in alternate layers of wood and stone

This arrangement divides the structure into four parts and provides for joists supporting the floorboards in each floor of the building. The wooden members are 6-9" thick and 1' wide. The two battens are joined together by nogging or straps and in-filled with stone rubble. On the first and second floor, the heavy stone masonry is surrounded by a balcony on all the four sides to allow sun (fig. 5.4). Wooden battens are supported on the walls which carry the wooden floors.

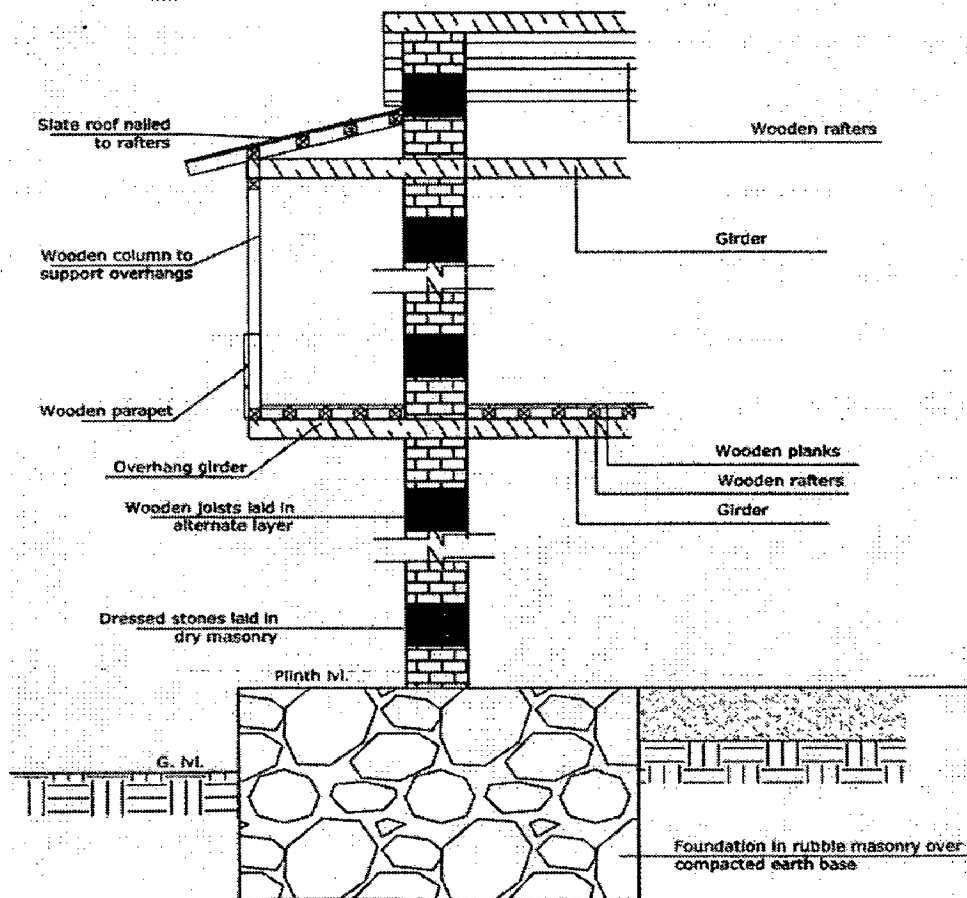

Figure 5.4 Section of typical house in Kinnaur

5.2.2. ANALYSIS OF TRADITIONAL CONSTRUCTION TECHNIQUES

The sustainability of Kath kunni for this region is analysed in terms of climatic response, material suitability and seismic suitability to assess its appropriateness

A. Climatic Response

- The thick wall construction in traditional Kath-kunni construction in the region is apt to withstand the cold but the changing climates have led to a shift in the appropriateness of this construction technique.
- The lower storey was used for storage and rearing cattle by the traditional agriculturist but with the shift in the occupation in the region, the lower floor is not properly used.
- The thick wall in the ground floor is not healthy for living conditions since there is no provision of daylight and ventilation.
- The traditional houses have smaller openings on the upper floors but these are ineffective in creating comfortable conditions in rainy season.

B. Material Suitability

- Materials like wood and stone are now scarce due to shrinking forests and restrictions on quarrying stone and thus unavailable for constructions.
- The thick logs of wood are not readily available and thus their suitability is less. However, use of thinner battens of wood may provide an opportunity for future application.
- Mud mortar used in the interior is slowly losing its appeal with the people due to its need for maintenance.
- Use of slate as a roofing material is also difficult since the availability of slate in the region is getting tough.

C. Structural and Seismic Stability

- The structural stability of this type of construction is more due to the provision of wooden battens in the structure. These battens provide ductility to the otherwise rigid construction.

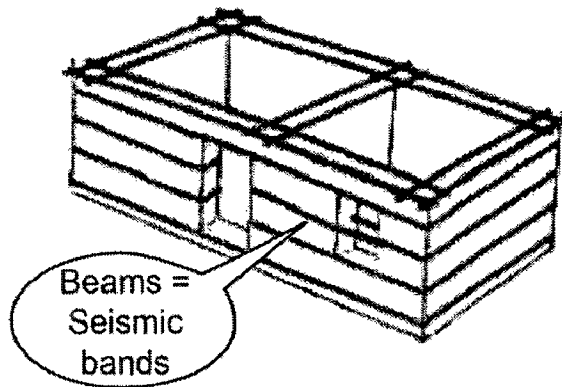

Figure 5.5 Provision of alternate bands provide seismic stability

Source: Schacher, Tom (2007), "Battar Handout", Swiss Agency for Development and Cooperation Architecture & Developpement French Red Cross United Nations Human Settlements program UN Habitat Earthquake Reconstruction & Rehabilitation Authority (Pakistan)

- Vertical load is taken care of by 1.5 ft or 2 ft. thick walls running in all four directions and horizontal load being taken care of by interconnected wooden joists running in both directions.
- The thick stone masonry is susceptible to move out of place if the stone are not laid out with proper bonding. But the total collapse of the structure can be avoided with the properly jointed wooden members.
- Wooden members often become susceptible to breakage due to improper joints between the members. The members are tenon and mortise jointed at the end of the batten which is weak. For better structural safety, wooden battens should be left with nosing at the corners.
- Heavy roof may collapse in the advent of an earthquake since slates are laid over each other without proper nailing to the rafters.

5.2.3. TRADITIONAL CONSTRUCTION TECHNIQUES IN SHIMLA

Shimla is nestled in the hills with the elevation range from 300 metres (984 ft) to 6,000 metres (19,685 ft). The topology is rugged and tough. The climate in Shimla is predominantly cold during winters and moderately warm during summers. The average total annual precipitation is 1520 mm region also receives snowfall in the month of December and January [16]. The buildings in the region are designed primarily to keep out the cold. The construction techniques in the higher ranges is closely related to the Kath- kunni technique of Kinnaur while the lower ranges show a variation in the

technique due to unavailability of long sleepers of wood for construction. A typical house is built with a wooden frame with an infill of stone with mud mortar which is called Dhajji wall construction.

It is built over a foundation of stone with 1 mt high plinth. The plinth beam or 'dassa' is laid over the plinth through anchoring it to the stone masonry. The perpendicular beam is joined with a lap joint at the corner and the vertical wooden post is joined to the plinth with tenon and mortise joint making a firm joint at the corner. (Fig. 5.6) At times straps are used to give a stable joint.

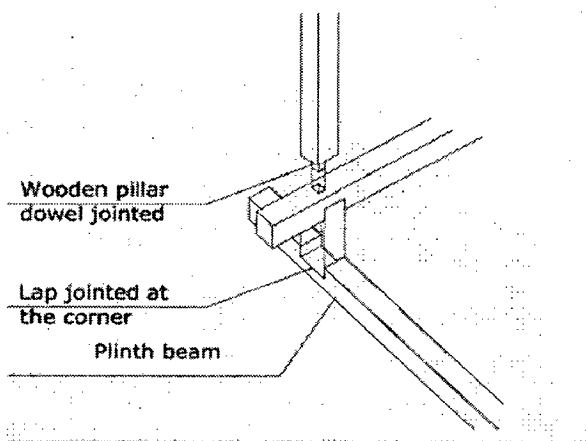

Figure 5.6 Corner detail

The vertical members of the frame are erected 4-6' apart. The sturdy frame is built with the braces and struts which are joined as shown in the fig. 5.7. The smaller partitions formed by the braces and the struts are filled with rubble masonry with mud mortar or mud bricks. The walls are 4- 6" thick and plastered with mud mortar mixed with twigs for better stability. The floor is laid over wooden rafters supported on the wooden wall plate. Wooden members are lap jointed and supported on wooden posts with a decorative wall plate. Walls are connected with a tie beam at the roof and slate roof is laid over wooden rafters and purlins.

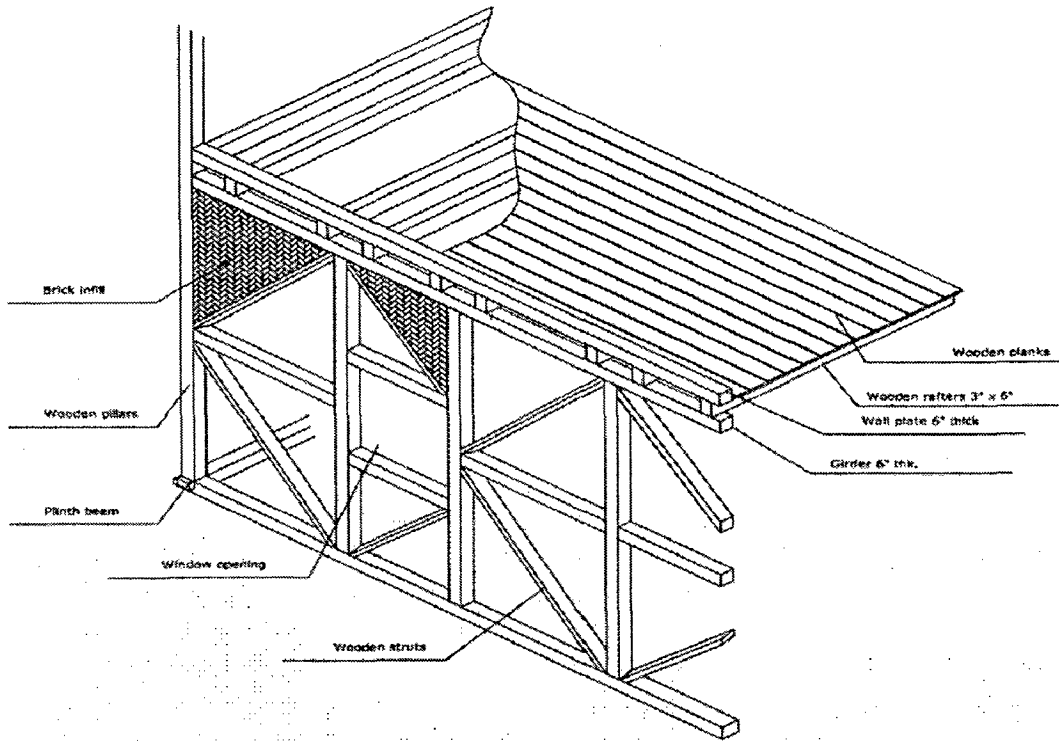

Figure 5.7 Dhajji wall frame

5.2.4. ANALYSIS OF TRADITIONAL CONSTRUCTION TECHNIQUES

Appropriateness of Dhajji wall construction higher Himalayan region is assessed under climatic response, material suitability and structural and seismic suitability for their significance in ensuring sustainability.

A. Climatic Response

- Dhajji construction provides a good insulation from cold and the provision of openings also allows the day light and sun to come in.
- Protection from water is very important since the wooden strength is reduced many fold in case of moisture content and without the provision of a water proofing of the plinth beam, this type of construction is not suitable for areas with higher rainfall.
- Mud plastering is susceptible to wash out in case of heavy rains. Using stabilisers can make the plaster long lasting.

B. Material Suitability

- This type of construction provides an efficient and economical use of materials. The use of wood is kept to a minimum.

- This construction is more material sensitive since it requires thinner pieces of wood for framework. The stone used for infill is also desired to be irregular and smaller in size which is easily available in the region.
- The mud mortar used for plastering is not readily accepted by the people in the present context which renders difficulty in using this technique extensively.

C. Structural and Seismic Stability

N. Gosain and A. S. Arya describe seismic performance of Dhajji wall construction: *“The timber runners...tie the short wall to the long wall and also bind the pier and the infill to some extent. Perhaps the greatest advantage gained from such runners is that they impart ductility to an otherwise very brittle structure. An increase in ductility augments the energy absorbing capacity of the structure, thereby increasing its chances of survival during the course of an earthquake shock. This was substantiated by the observation that “dhajji-dewaris” in which a larger volume of timber was used were comparatively safer.”*[18]

- The timber frames in the Dhajji walls when well constructed with a system of diagonal bracings provide a distinct path to the ground for the stresses caused by lateral seismic forces. In addition, the walls are lightweight and hence have less mass and less lateral seismic loads.
- The smaller partitions formed in the frame gives it rigidity in case of an earthquake (Fig. 5.8)

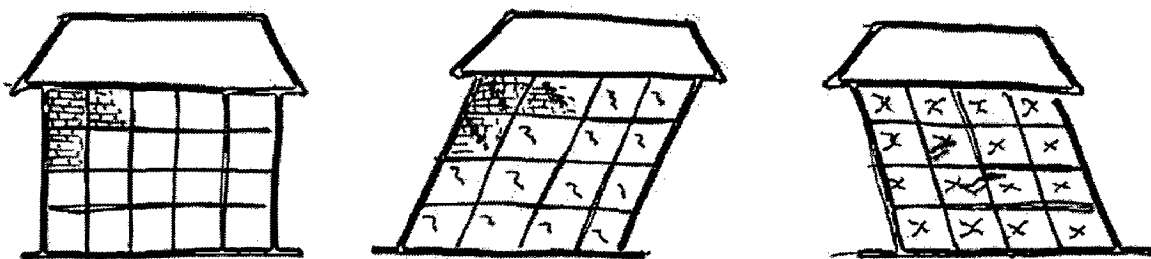

Figure 5.8 Behaviour of Dhajji wall under seismic loads

Source: “Basic training on dhajji construction” [http://www.traditional-is-modern.net/LIBRARY/SCHACHER-lessons/Schacher-DhajjiLesson\(8.3.07\)\(s\).pdf](http://www.traditional-is-modern.net/LIBRARY/SCHACHER-lessons/Schacher-DhajjiLesson(8.3.07)(s).pdf).

- The structural safety of the construction is dependent on the workmanship in making the joints. Inadequate nosing or lap joints can make the frame very weak.
- The floor rafters and planks are supported on the wooden posts through a point load which makes it very susceptible to structural failure.

5.2.5. TRADITIONAL CONSTRUCTION TECHNIQUES IN MANALI

Manali lies in the Beas valley at an elevation on 1950 mt. The climate in Manali is predominantly cold during winters and moderately cool during summers. The average total annual precipitation is 1,520 mm. [19] It receives both winter and summer rains. Snowfall occurs in the month of February. The region is bestowed with dense forests which yield good construction wood.



Figure 5.9 Typical wooden house in Manali

The house is planned on a rectangular form with the front porch or balcony and the rooms laid out in a series. The walls are made with a wooden frame resting over a plinth 1' high made of random rubble masonry. The wooden plinth beam rests on the plinth anchored to the foundation. Vertical posts are erected 6' apart and joined through tenon and mortise joints. The horizontal braces are provided at regular intervals. In case of opening, the horizontal braces are provided at the sill and lintel and the boards are nailed to them. (Fig 5.10) Frame is covered with vertical planks nailed into the frame. A plank is laid over the bottom and top of the vertical planks to protect against weathering. Floor is supported on the girder and the rafters run perpendicular to the girder. Roof is made of slate laid on wooden girders. In some houses, the lower floor is made of mud walls while

the upper floor is constructed with timber. A section through a wooden house is shown in fig. 5.11. The mud wall is made with sun dried mud bricks 1-2' wide laid as in mud construction.

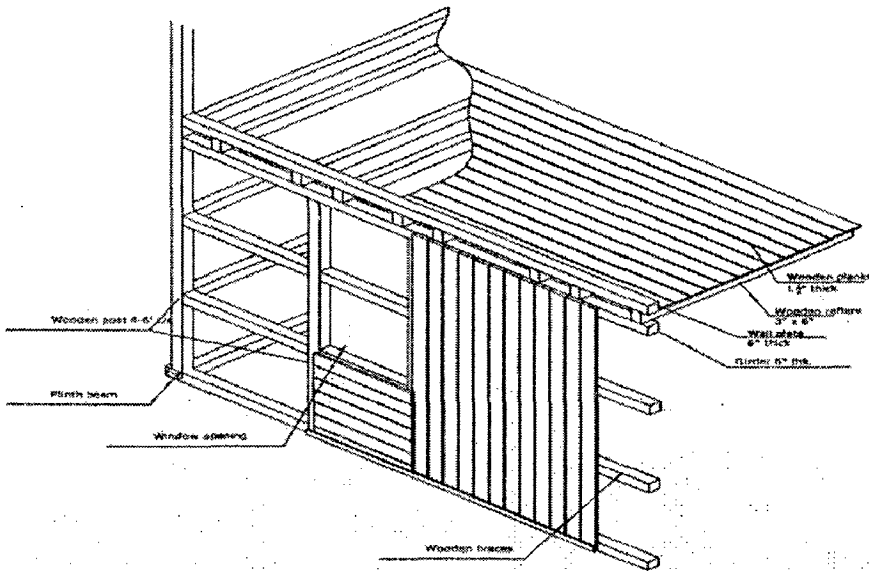

Figure 5.10 Wooden frame and construction

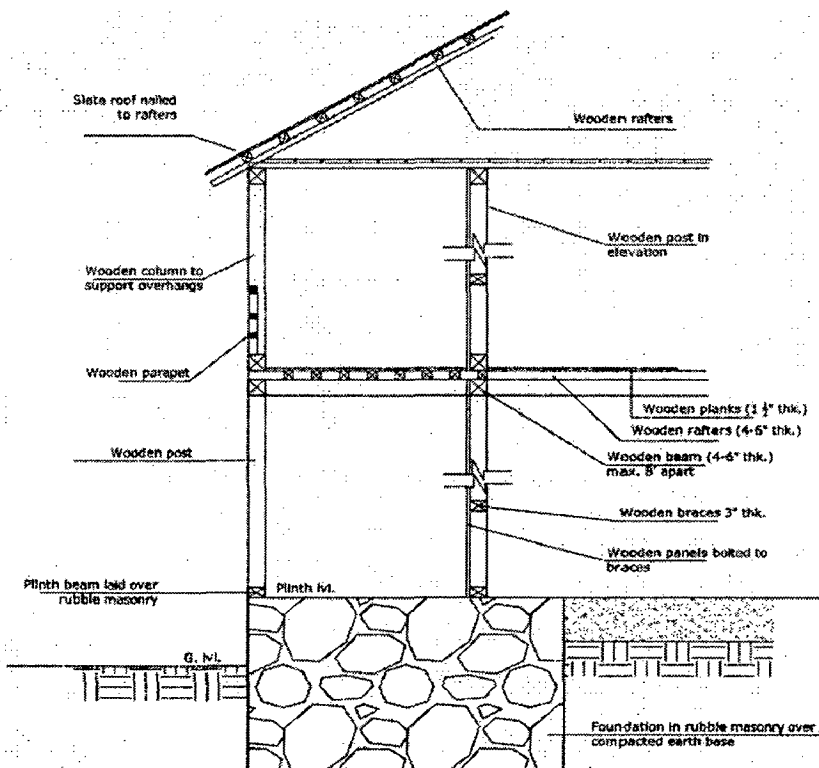

Figure 5.11 Section through typical wooden house

5.2.6. ANALYSIS OF TRADITIONAL CONSTRUCTION TECHNIQUES

Appropriateness of the wooden wall construction in Manali in higher Himalayan region is assessed under climatic response, material suitability and structural and seismic suitability for their significance in ensuring sustainability.

A. Climatic Response

- The house is adapted to the climate since wood is a good insulator of heat which does not allow the heat to enter in summers and keeps the heat inside in winters.
- Light structure allows provision of ventilation and lighting.

B. Material Suitability

Extensive use of wood in the present context is a problem however, in case reclaimed wood or wood from certified forests is used, this technique can be used in the region.

C. Structural and Seismic Stability

- The wooden frame is very stable in case of an earthquake.
- The floor rafters and planks are supported on the wooden posts through a point load which makes it very susceptible to structural failure.
- The structural safety of the construction is dependent on the workmanship in making the joints. Inadequate nosing or lap joints can make the frame very weak.(fig 5.12)

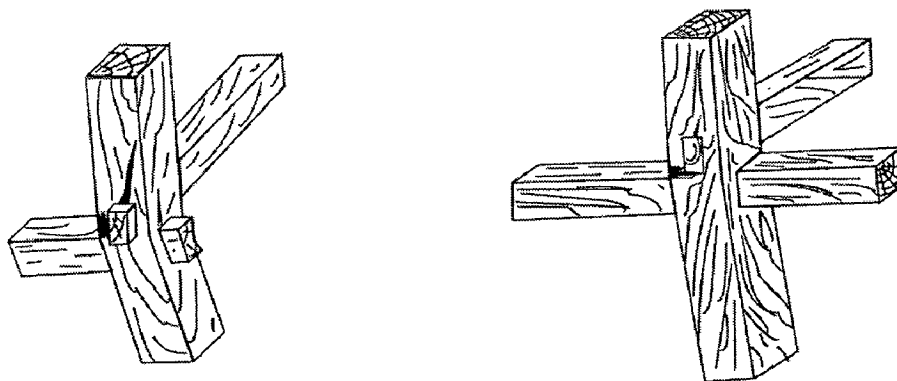

Figure 5.12 Failures in wooden frame due to inadequate nosing

Source: Guidelines for earthquake resistant non- engineered construction (2007), National Information Centre for Earthquake Engineering

5.2.7. TRADITIONAL CONSTRUCTION TECHNIQUES IN CHAMBA

Chamba is situated on the northern bank of river Ravi which is prone to floods. The average annual rainfall in the town is 785.84 millimetres [20]. Though it does not receive snowfall but the winters are chilly and summers warm. The region has large expanse of wood and stone is recovered from the river beds. A typical house in Chamba valley is built in a rectangular form with living areas laid next to each other and a porch is created with the balcony on the first floor. (Fig. 5.13)



Figure 5.13 A typical House in Chamba

The walls are made of stone in mud mortar about 2 ft. thick with the columns made in the *faroque* style. (Fig 5.14) The columns are 2 ft. thick with 6" thick planks laid on two parallel sides and the upper layer lay perpendicular to it forming a box type structure which is filled with dry rubble masonry. The wooden planks are not jointed but are erect under their self weight. The walls and columns are then plastered with mud plaster.

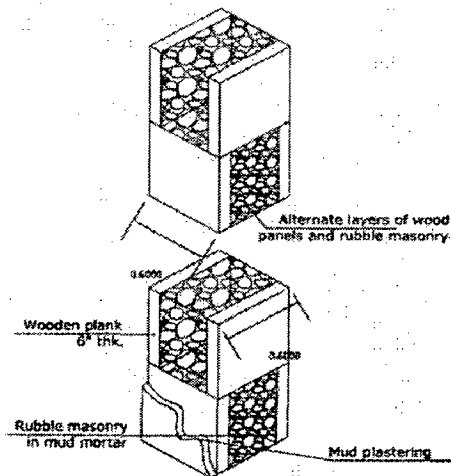

Figure 5.14 Detail of the column

The house is generally two storeyed with each storey having kitchen which is used in different seasons. The balcony rests on the columns and the wooden posts in the front. (Fig. 5.15) Roof is laid with slate over wooden rafters.

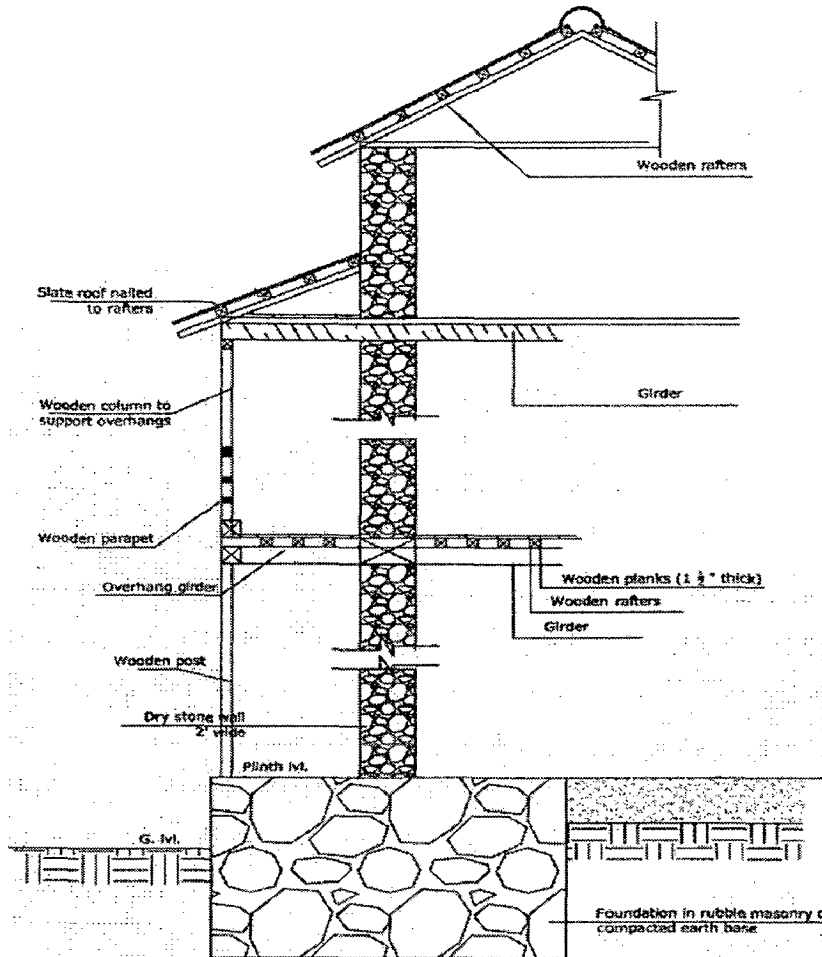

Figure 5.15 Section of typical house in Chamba

5.2.8. ANALYSIS OF TRADITIONAL CONSTRUCTION TECHNIQUES

An appraisal of traditional construction techniques in Chamba in terms of climatic response, material suitability and structural and seismic suitability is done to assess its suitability in the region.

A. Climatic Response

- The traditional house is built for safeguarding against the cold. The thick walls provide protection from the chilly winds.
- The house does not have any provision for ventilation and daylight.
- The higher plinth safeguards against rain as well as snow.

B. Material Suitability

Stone is the maximum used material which is not easily available in the region these days due restriction on quarrying.

C. Structural and Seismic Stability

- The columns made with faroque technique are not properly jointed and seem unstable.
- The wooden posts are not provided with any plinth beam which makes is unstable in case of an earthquake.
- Heavy roofing makes this type of construction prone to collapse.
- The rubble masonry in the absence of any confining member of wood is susceptible to collapse under earthquake. (fig. 5.16)



Figure 5.16 Damage caused due to collapse of stone wall

5.3 MODERN CONSTRUCTION PRACTICES IN HIGHER HIMALAYAN REGION

The changing times and advancements in technology and the aspirations of the people have allowed the use of fired brick masonry, cement concrete and R.C.C structure. This allows buildings of more than 2 stories and thus is gaining popularity in the region. Modern houses are built irrespective of the steep slopes of the region as is seen in the fig. 5.17.



Figure 5.17 Typical modern concrete house in Higher Hiamalayas

5.3.1. ANALYSIS OF MODERN CONSTRCUTION TECHNIQUES

The sustainability of modern construction techniques for this region is analysed in terms of climatic response, material suitability and seismic suitability to assess its appropriateness.

A. Climatic Response

- Modern construction techniques have not been adapted to the cold climate of the region. Many R.C.C houses are left unoccupied in the chilly winters.
- The one brick wall construction prevalent in the region is incapable of keeping the interiors insulated in hotter regions also.
- Brick wall construction works well for the protection against the rain in the region.

B. Material Suitability

The materials used in modern construction are not local to the region and are needed to be imported which adds to the cost of construction and the energy utilised by the building.

C. Structural and Seismic Stability

- The houses are not built as per the earthquake guidelines which make them vulnerable to earthquakes. Lack of provisions like plinth band and lintel band makes them unsafe.

- Multi- storeyed structures built without codal provisions are a major disaster risks.
- The houses built in the region have been found to be made with the materials of lesser grade and the construction joints in the structural members also tend to be faulty causing failure in case of any disaster.

5.4 ALTERNATE CONSTRUCTION TECHNIQUES IN HIGHER HIMALAYAN REGION

As an objective to adopt the traditional construction techniques with the modern materials, some steps have been taken. The use of Dhajji wall construction with the cement concrete bands and the use of cement instead of mud mortar are few of the techniques developed.

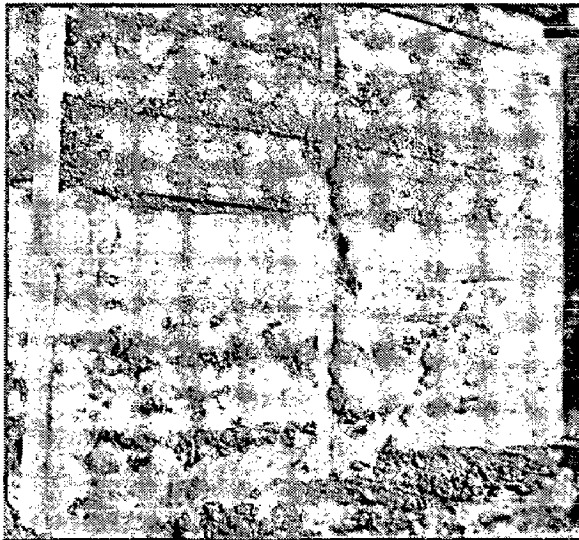

Figure 5.18 Cement concrete as an infill in wooden frame

5.4.1. ANALYSIS OF ALTERNATE CONSTRUCTION TECHNIQUES

An appraisal of alternate construction techniques in terms of climatic response, material suitability and structural and seismic stability is done to assess its suitability in the region.

A. Climatic Response

- The use of cement mortar makes the structure more durable since it does not wash out with the rains.

- Use of concrete as filling is not in compliance with the climatic conditions of the region. Concrete does not allow the heat to be retained with the use of a layer of insulation.

B. Material Suitability

Materials like cement are not locally available to the region but if used judiciously, they can be effective in providing durable construction.

C. Structural and Seismic Stability

- These houses are not structurally safe. Use of rigid infill like cement concrete does not provide the same ductility to move freely in case of an earthquake.
- Use of mud mortar allows the infill stones ductility and energy of the seismic forces is dissipated in the form of friction between the infill.
- Improper provision of braces to form smaller infill panels makes the construction structurally unstable. The stability of this construction lies in the well bonded frame which provides a rigid structure.

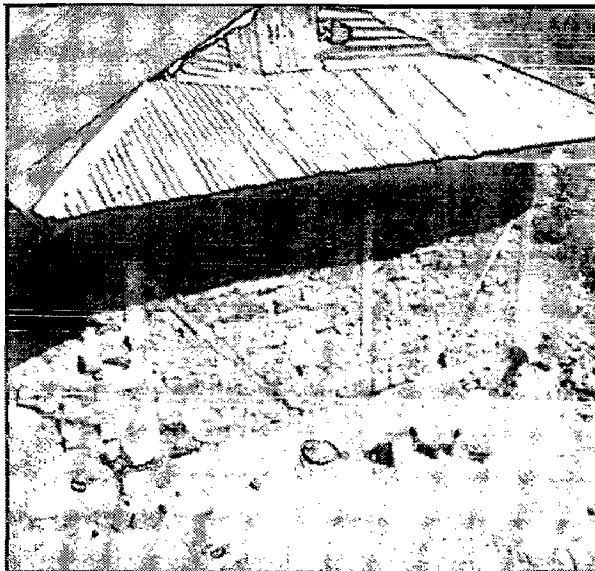

Figure5.19 Improper provision of braces

5.5 SUMMARY

Traditional construction techniques prevalent in the higher Himalayan region are efficient in safeguarding against the cold but these techniques are unfitting in the present context as the materials employed in these techniques are not available for construction. However, the knowledge embedded in these techniques to resist the earthquake tremors are a lesson to be learnt. Modern construction techniques on the other hand have not evolved into climatically suitable construction. There is scope to evolve these traditional construction techniques with modern materials as an alternate technique to be employed in the region as sustainable construction. Prevalent techniques of lower Himalayan region are discussed in the following chapter.

CHAPTER 6: PREVALENT TECHNIQUES IN LOWER HIMALAYAN REGION

6.1 INTRODUCTION

The Lower Himalayan region is marked by slight slopes and plain areas. It comprises of lower ranges of Kangra, Una, Hamirpur and Sirmour. Due to its proximity to the plains, this region experiences cool winters but hot summers. Heavy monsoons occur in the months of July to August. Mud for construction and stone for rubble masonry are easily available. For the study, region of Kangra is identified where all three categories of. This chapter is dedicated to the study of the modern, traditional and alternate construction techniques prevalent in the lower Himalayan region. An assessment of these techniques in the region is also done in terms of climatic response, material suitability and structural and seismic stability.

6.2 TRADITIONAL CONSTRUCTION PRACTICES IN KANGRA

The region has both hilly as well as plain terrain with the average elevation of 733 metres and is formed by the basins of three rivers Bener River and Majhi River, and Beas. [18] Climatically, Kangra is hot in the summers with comfortable winters while certain regions receive very heavy rainfall in the monsoon. Mud and wood are easily available in the region which is thus used in the traditional construction. A typical traditional house is laid in square or rectangular form with the living areas laid around the kitchen which is the main activity zone.



Figure 6.1 A typical traditional mud house

A typical house in Kangra is built with mud walls and wooden floors. A thick rubble stone masonry is used for foundation. (Fig. 4.22) 2' thick mud wall is made with sun dried mud bricks with mud mortar. Floor rests on the load bearing walls and the wooden planks are laid over the rafters. Floors are finishes with mud mortar mixed with twigs and then a layer of mud mortar slurry and cow dung makes the floor last longer. Walls are also treated with the mud and cow dung slurry upto a height of 3 feet on the inside and the external wall. Roofs are laid with slates attached on wooden members.

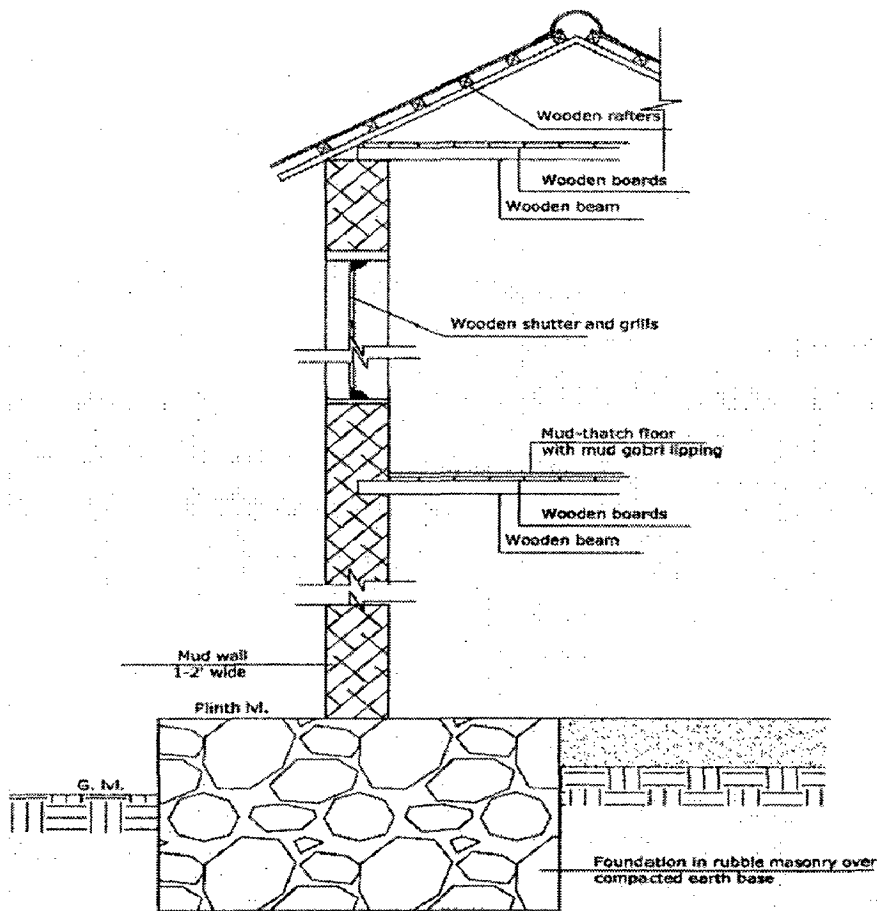

Figure 6.2 Section through mud wall

6.2.1. ANALYSIS OF TRADITIONAL CONSTRUCTION TECHNIQUES

The sustainability of traditional mud construction for this region is analysed in terms of climatic response, material suitability and seismic suitability to assess its appropriateness

A. Climatic Response

- Use of mud keeps the internal temperature comfortable in the hot summers.
- Due to improper ventilation inside, the moisture may affect the mud wall.
- Mud flooring insulates the floor and does not allow dissipation of heat.

B. Material Suitability

- Mud construction is not perceived as a pukka construction since there is need for maintenance after a shower.
- Sun dried bricks are more energy efficient since it does not need fuel burning for its manufacture.

C. Structural and Seismic Stability

- Mud construction is monolithic thus should perform well structurally. However, thick walls tend to be prone to earthquake damage.
- Absence of any wall plate or horizontal member makes the wall susceptible to earthquake.
- Higher walls and heavy roofs in traditional houses can succumb to failure. (fig. 5.3)



Figure 5.3 Failure in mud walls

6.3 MODERN CONSTRUCTION PRACTICES IN LOWER HIMALAYAN REGION

Modern construction of fired brick, cement concrete and R.C.C is common in the region. Easy access to the materials from plains has shown a rise in the constructions with bricks and cement. Extensive use of glass results in higher heat gains and thus creating uncomfortable conditions in summers. This type of construction allows buildings to be maintenance free and high rise structures are also possible. (fig. 6.4)



Figure 6.4 A modern building in Kangra valley

6.3.1 ANALYSIS OF MODERN CONSTRUCTION TECHNIQUES

The sustainability of modern construction techniques for this region is analysed in terms of climatic response, material suitability and seismic suitability to assess its appropriateness.

A. Climatic Response

- Fired brick wall construction with flat R.C.C roof is not climatically adapted to the region. These structures do not provide protection against the hot summers.
- Brick wall construction works well for the protection against the rain in the region.

B. Material Suitability

Materials like fired brick and cement are available in the near by regions.

C. Structural and Seismic Stability

- The houses are not built as per the earthquake guidelines which make them vulnerable to earthquakes. Lack of provisions like plinth band and lintel band makes them unsafe.
- The houses built in the region have been found to be made with the materials of lesser grade and the construction joints in the structural members also tend to be faulty causing failure in case of any disaster.

6.4 ALTERNATE CONSTRUCTION PRACTICES IN LOWER HIMALAYAN REGION

Use of mud construction with the use of cement is a technique practised by an American architect working in the region. A typical house was studied and the appropriateness of these techniques analysed.

House is designed on the modular formula where the maximum length of the wooden beam is a module. House is built over a bed or rubble masonry bonded with mud plaster. At the plinth, R.C.C beam 450 mm high is laid for earthquake safety. Over the plinth beam, walls 2' wide are erected in sun dried brick wall in masonry. Wall is provided with a layer of cement plaster upto 1 m high as damp protection. (fig. 6.5) To counter the problem of washing out with water three layers of plastering is done. First layer consists of traditional mud plaster. After drying, thin slurry of mud is applied. This layer fills the cracks developed in the plaster. After that, a layer of mud plaster mixed with twigs and cow dung with stabilisers is applied.

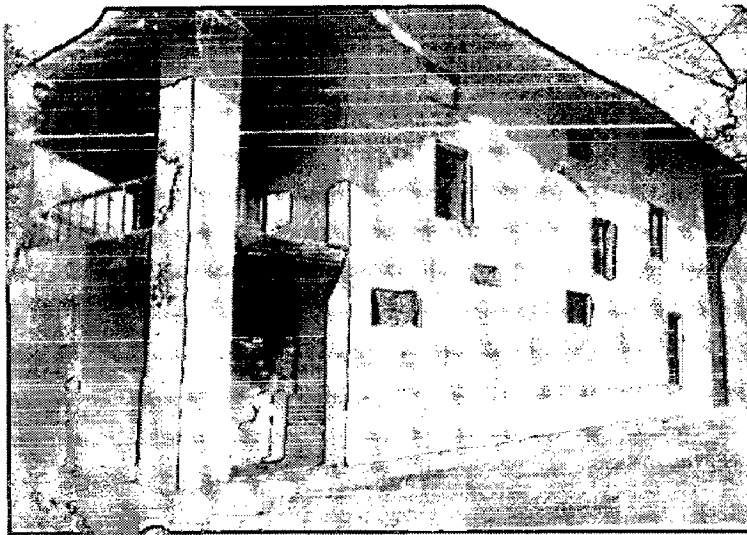

Figure 6.5 View of alternate mud house

At the lintel and also at the eaves level, cement beams are provided. Floors are laid over smoked bamboo purlins which are not damaged by insects and moisture. Over the bamboo, 'chira' half bamboo or bamboo mat is laid which is covered with a wire mesh and poured with the mud slurry. Wire mesh binds the mud mortar and provides reinforcement. Walls in the wet areas like toilets are made of fired brickwork and the flooring is done in stone. Roof is laid in the same fashion as the traditional construction with slate placed over bamboo rafters. (fig. 6.6)

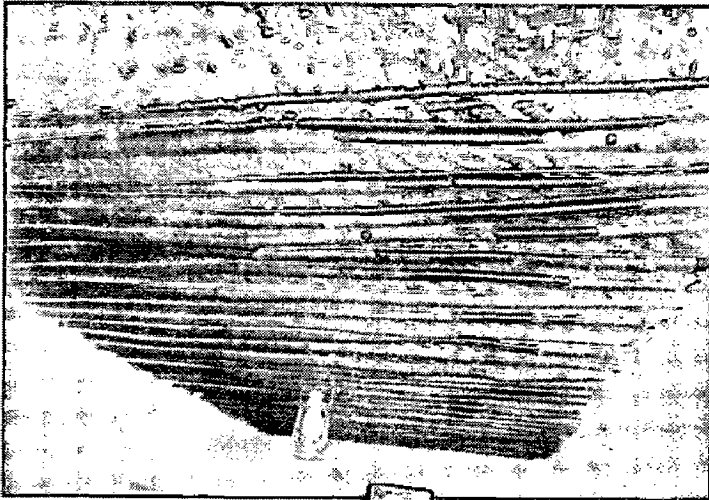

Figure 6.6 Floor from below

6.4.1 ANALYSIS OF ALTERNATE CONSTRUCTION TECHNIQUES

An appraisal of alternate construction techniques in terms of climatic response, material suitability and structural and seismic suitability is done to assess its suitability in the region.

A. Climatic Response

- Use of mud construction is appropriate for the climate of the region.
- The use of cement as plinth protection counters the problem of damage due to heavy rains.
- Not enough provision for ventilation creates damp conditions inside during rainy season.

B. Material Suitability

- Use of mud as a construction material is both energy efficient and cost effective. The techniques available in the market to make mud buildings long lasting can provide great boost to this technology.
- Acceptability of mud as a construction material has changed in the recent times.

C. Structural and Seismic Stability

- For seismic resistance, horizontal bands of cement concrete are provided at different levels which gives this construction structural stability.
- Performance of the thick mud wall under seismic loads is a concern.

6.5 SUMMARY

Traditional construction techniques in the region are energy sensitive for their use of local material but the problems of maintenance have caused a fall in their priority in the region. However alternate construction techniques are able to counter this problem. Modern materials and finishes are now available which can make these traditional techniques more appropriate for the changing living standards and aspiration of the people in the region. Keeping this in view, an attempt is made here to evolve these techniques using modern construction materials which may provide an answer to the local needs of the people and also the need for a sustainable in the following chapter.

CHAPTER 7: CONCLUSION, RECOMMENDATION AND FUTURE POTENTIAL

7.1 INTRODUCTION

Traditional construction techniques and materials were evolved as a response to the local climate and availability of materials. But with the advances in the field of technology, availability of new materials and changing aspirations of people, modern construction techniques and materials are gaining importance in the state. There is a shortage of traditional materials, knowledge and workmanship making the traditional construction techniques redundant in the present times. Keeping in mind the benefits of the traditional techniques and the problems encountered in the use of traditional materials, an attempt is made to combine the traditional knowledge and the modern technology for a sustainable living environment as an answer to the needs of the people.

7.2 CONCLUSION

- Traditional construction techniques vary with the variation in geography and climate. Himachal Pradesh consists of steep slopes and harsh climatic conditions. Traditional construction techniques thus adopted involved use of site conditions to its benefit. Houses were built on solid ground and planned to as to allow minimum alterations in the site. Walls were constructed with the local materials to blend with the local context. Thick walls are a characteristic of cold climates and are also traditionally practiced in all regions of the state to allow a larger time lag for the heat to escape into the outside environment.
- Different region in Himachal vary in their adoption of different materials and techniques in traditional construction. This variation is mainly due to the availability of material. Regions bestowed with abundance of wood and stone use them in the construction of walls as well as foundations. Thick logs of wood are used as structural members while is areas where thick logs are not available, a wooden framed structural system is adopted. In the regions where vegetation is sparse have adopted mud as a traditional construction material. Thick mud walls constructed by ramming or in the form of sun dried bricks provide thermal insulation thus keeping the interiors warm.

- A survey of prevalent construction techniques in different regions of Himachal Pradesh allowed one to conclude that the traditional construction techniques like Kath-Kunni and Dhajji wall are climate responsive and structurally stable but the use of thick logs of wood for these techniques is not viable in the present context. On the other hand, the modern construction techniques have not adapted to the local conditions. Innovation in modern materials, however, provides an opportunity to evolve a construction technique which can provide better climate appropriateness.
- Traditional techniques are a bank of wisdom and understanding of the local conditions. This study, however, concluded that the adoption of traditional construction techniques in their original form is not a viable solution. There is a need to combine this knowledge with modern materials and technology to provide a sustainable construction technique. The various factors influencing the applicability of traditional construction techniques in a modern context are discussed in detail later.

7.3 FACTORS GOVERNING THE APPLICABILITY OF TRADITIONAL CONSTRUCTION TECHNIQUES IN MODERN CONTEXT

Traditional construction practices were evolved from the local materials for the local conditions. In the present context, various factors are responsible for the decrease in application of these techniques. The following factors are concluded on the basis of this study.

- Influence of Availability of Material

Traditionally, the building materials used for construction were procured from the close by areas. Transportation of materials like thick logs of wood and stone was difficult over large distances. In the present times, wood is not easily available on site and due to environmental concerns like deforestation, should not be used in the construction in such large quantities. Stone is a scarce material due to the ban on quarrying of stone in the state. Thus the choice of technology for new construction should use these scarce materials judiciously.

- Influence of New technologies

Various new technologies like prefabrication and modern materials like concrete blocks and flyash bricks which have a smaller impact on the environment are available which give an opportunity to use them for a sustainable living environment. There is a decline in the traditional know how and the modern construction practices are not carried out by the trained professionals. In the absence of professionals, construction technique adopted should be an offshoot of traditional knowledge and easy to fabricate so that the locals are able to build a suitable house.

- Influence of Cost of Construction

Traditional materials are costly to procure and with limited trained people for these techniques, construction with traditional techniques is a very costly endeavour. Traditional construction techniques in the absence of modern technology involve use of thicker walls for effective protection from the cold. This reduces the carpet area and thus the space utilization is not economic. Increasing population and limited land sources do not allow uneconomic use of land. Materials used for new developments should perform same as the traditional material and allow maximum utilization of the land available.

- Influence of Earthquake Safety

Traditional construction techniques like Kath- kunni and Dhajji construction are found to be earthquake safe. But in the absence of professional expertise and maintenance, traditional buildings have incurred losses in the past earthquakes. Construction technique employed in new construction should be a lesson from the traditional knowledge about the seismic loads to make the buildings safe in case of an earthquake and other hazards.

- Influence of Sensitivity to Local Context

The choice of material and technique should fit to the local conditions of the region. Traditional techniques have effectively responded to the local climate and geomorphologic conditions. But the modern techniques are not sensitised to the harsh climate of Himachal. The materials and techniques adopted should reflect the local context and respond to the local needs.

- Influence of Public Attitude and Expectations

With the changing times, people's needs also change. Traditional craftsmanship is dying and lack of traditional knowledge has led to poorly maintained houses. Through the survey that was conducted, it was seen that many people left their mud and stone houses and built cement concrete houses as they found the traditional houses unsafe for living or unable to cater to their needs of bigger families. The higher economic status of people inspires them to build modern houses even though these houses are not climate responsive. Many people in the trans and higher Himalayan region tend to shift their homes in winters to the traditional houses since they are warmer. Materials and techniques chosen for new developments should not only cater to the environmental needs but also the people's aspirations for a safe home.

7.4 RECOMMENDATIONS IN FORM OF ALTERNATE CONSTRUCTION TECHNIQUE

The various factors stated above have lead to use of modern materials in the new construction techniques which are discussed as alternate construction techniques in Chapter 4. There are various other materials which are available which are used in the other region but can be used in Himachal too. Various agencies like Central Building Research Institute, Building Materials Technology Promotion Council, Development Alternatives, etc have enhanced the traditional building materials or developed new ones which are stable and more efficient than stone or adobe masonry.

Stone blocks are made by compacting the smaller stones into the mould and bonding with cement slurry. They have the similar thermal properties as stone thus can withstand the cold climate of Himachal. Modular nature of the stone blocks can facilitate minimum wastage. Plastering on the one or both faces of walls can be avoided thus reducing the cement used in the construction. In the earthquake sensitive zone of Himachal, use of heavy walls is not recommended thus, stone block masonry can provide a solution. But for earthquake safe construction, walls are meant to be integrated well with the structure of the building. thus it is recommended that building must incorporate vertical and horizontal bands to allow dissipation of energy in case of an earthquake. Keeping all these factors in mind, use of prefabricated concrete beams and wooden braces can provide a unified structural system. Provision of reinforcement in the corners can avoid any junction failures.

The construction of stone or concrete blocks masonry with mud or cement mortar has been newly introduced in rural and urban areas in other regions. The performance of such buildings has been, in general, better than that of the stone masonry buildings. Masonry works in buildings with lintel bands of cement concrete or wood performed in a better way both seismically and climatically.

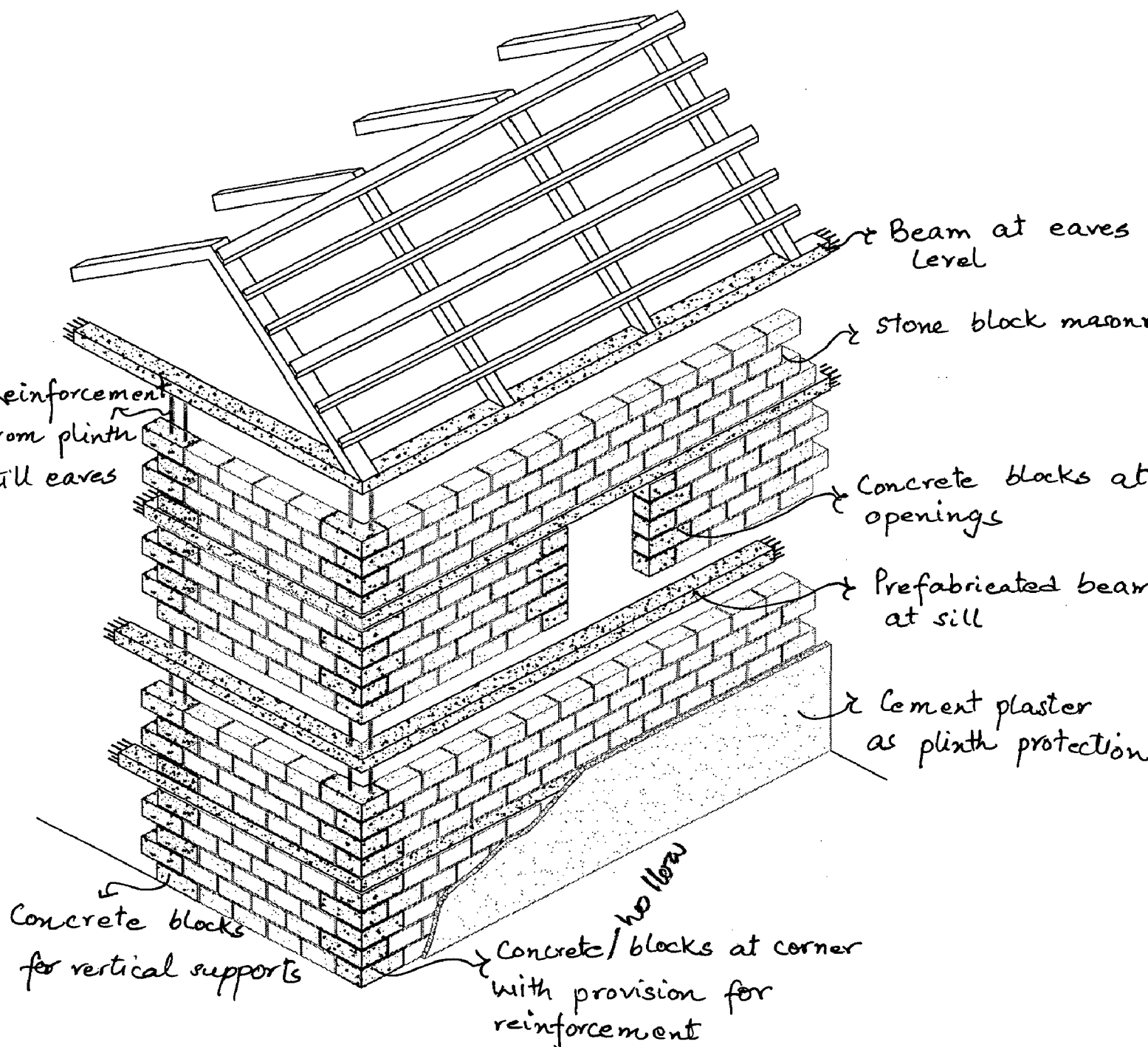

Figure 7.1 Sketch showing use of stone blocks, concrete blocks and prefabricated beams as a potential construction technique

BIBLIOGRAPHY

- Abbott, D., (1980) "Hill Housing", Granada London
- Aggarwal, A., (1982) "Research: Mud as traditional building material", In *The Changing Rural Habitat; Volume I: Case Studies*. Brian Brace Taylor (ed). Singapore: Concept Media/The Aga Khan Award for Architecture.
- Alexander André, Catanese Andreas (2007) "The Restoration of Tsas Soma Mosque, Leh, Ladakh, India: a report", www.tibetheritagefund.org
- Baker Laurie (1986), "Houses: How to reduce building cost", COSTFORD
- Baker Laurie, (1992) "Earthquake: Report on Uttarkashi Earthquake", Department of Science and Technology
- Baker Laurie, "Brickwork", COSTFORD
- Baker Laurie, "Mud", COSTFORD
- Brunskill R.W (1970) "Illustrated handbook of Vernacular Architecture", Faber and Faber,
- Burte Himanshu., (2007) "Not by the book: Alternative approaches", *The wall street journal*, livemint.com
- Dasgupta Arunava, "The Himalayan Vernacular: An architectural journey towards its future".
- Desai Rajendra, Desai Rupal (2007) "Manual for Restoration and Retrofitting of Rural Structures in Kashmir", UNESCO & UNDP
- Fathy, Hassan. 1992. "Contemporaneity in the City". In *Architecture for a Changing World*. James Steele (ed). London: Academy Editions.
- Givoni, B. *Man, Climate and Architecture*. Amsterdam: Elsevier Publishing Company Limited, 1969.
- Handa, O.C, "Panorama of Himalayan Architecture Vol. 2", Minerava Book House Shimla.
- Holod, Renata and Darl Rastorfer. 1985. "In His Own Words". In Hassan Fathy. Singapore: Concept Media, 147-152.
- Jain, M.; Inderpal Singh; (2007) "Sustainability and Traditional Buildings", *Architecture-Time Space & People*
- Jain, Minakshi et al (2005) "Traditional Architecture and Planning Techniques in Himachal Pradesh", *Institution of Engineers (India) Journal-AR*.

- Jigyasu Rohit (2000), "From cultural to natural disaster: Consequences of post-earthquake rehabilitation process on the cultural heritage of Marathwada region, India", UNESCO-ICOMOS Conference on "Earthquake safe: Lessons to be learnt from traditional construction"
- Jigyasu Rohit (2008) "Recovering Indigenous Knowledge for Safer Schools", International Conference on School Safety, Islamabad (Pakistan)
- Kimura Ken-ichi, (1994), "Vernacular technologies applied to modern architecture", Renewable Energy, Vol.5, Part II, pp. 900-907
- KUMAR *et al.*, (1993) "Cooling techniques in a passive solar house", Energy Convers. Mgmt Vol. 35, No. 8, pp. 671-682,
- Kumar, P.S, (2009) "Breaking through the conventional barriers", epaper.dnaindia.com
- Langenbach Randolph (1992) "The earthquake resistant mud and brick architecture of kashmir" Traditional Southwest Magazine
- Langenbach Randolph (2007), "From Opus Craticium to the "Chicago Frame: Earthquake-Resistant Traditional Construction" International Journal of Architectural Heritage
- Morel J.C., et al. (2001), "Building houses with local materials: means to drastically reduce the environmental impact of construction", Building and Environment ,1119–1126
- N. Engin, N. Vural, S. Vural, M.R. Sumerkan, (2005) "Climatic effect in the formation of vernacular houses in the Eastern Black Sea region", Science Direct
- Nath Rituraj,(2010) "Assam Type House – The Traditional Earthquake Resistant Construction Practice In Assam", National Seminar on Disaster Mitigation in Housing in India.
- Pich-Aguilera, Felipe. (1989) Hassan Fathy: Beyond the Nile. In MIMAR 33: Architecture in Development. London: Concept Media Ltd.
- Rastorfer, Darl. (1985) "The Man and His Work". In Hassan Fathy. Singapore: Concept Media, 25-39.
- Representative designs of energy-efficient buildings in India, Tata Energy Research Institute
- Richardson, V. "New Vernacular Architecture", Watson-Guptill Publications

- Serageldin, Ismail. (1985) "An Egyptian Appraisal" In Hassan Fathy, Singapore: Concept Media, 15-24.
- Sharma Anupama, Dhote K K (2003) "Thermal Comfort and Heritage Building", Institute of Engineers Journal
- Sikka Sandeep, Chaudhry Charu (2009) "Climate Change in Western Himalaya Impacts, Mitigation And Adaptation Of Historic Earthen Structures", Scientific Symposium, 2009 : Changing World, Changing Views of Heritage
- Singh Manoj Kumar, (2009) "Bioclimatism and vernacular architecture of north-east India", *Building and Environment* 878–888
- Taragan, Hana. (1999) "Architecture in Fact and Fiction: The Case of the New Gourna Village in Upper Egypt". In *Muqarnas: An Annual on the Visual Culture of the Islamic World*, XVI, 169-178. Turner, L. *Climate and Architecture*, Florida State University, 2005
- Valsson Sheeba, Bharat Alka,(2008) "Climatic Considerations in planning - Inferences from past", *Architecture-Time Space & People*
- Yeomans David, (2001) "The Characteristics of Traditional Construction", Istanbul Paper.

WEBSITES

- http://en.wikipedia.org/wiki/Indian_ernacular_architecture
- <http://himachaltourism.gov.in/page/About-Himachal.aspx>
- http://en.wikipedia.org/wiki/History_of_Himachal_Pradesh
- <http://asc-india.org/menu/gquakes.htm>
- http://en.wikipedia.org/wiki/Vernacular_architecture
- http://www.arup.com/Projects/Druk_White_Lotus_School/Details.aspx
- <http://www.indiainfoweb.com/himachal-pradesh/architecture/>
- <http://lauriebaker.net/work/work/baker-on-laurie-baker-architecture.html>
- www.nbne.org/natbuild/cob.php

http://www.conservationtech.com/RL's%20resume&%20pub's/RL-publications/Equ-pubs/1989-APT-Bulletin/APT_art.htm

<http://www.unu.edu/unupress/unupbooks/80a01e/80A01E00.htm#Contents>

<http://www.saudiaramcoworld.com/issue/199904/the.legacy.of.hassan.fathy.htm>

<http://www.livemint.com/Articles/2007/10/11011246/Not-by-the-book-Alternative-a.html>

<http://www.vernarch.com/>

<http://tcdc.undp.org/sie/experiences/vol4/Rehabilitating%20indigenous.pdf>

<http://lauriebaker.net/work/work/bakers-architectural-principles.html>

<http://lauriebaker.net/work/work/alternative-building-materials-timeless-mud.htm>

http://www.dwls.org/Buildings_Photo_Gallery.html

http://www.serbianunity.net/culture/history/Hist_Serb_Culture/chk/Traditional_Architecture.html

The construction of stone or concrete blocks masonry with mud or cement mortar has been newly introduced in rural and urban areas in other regions. The performance of such buildings has been, in general, better than that of the stone masonry buildings. Masonry works in buildings with lintel bands of cement concrete or wood performed in a better way both seismically and climatically.

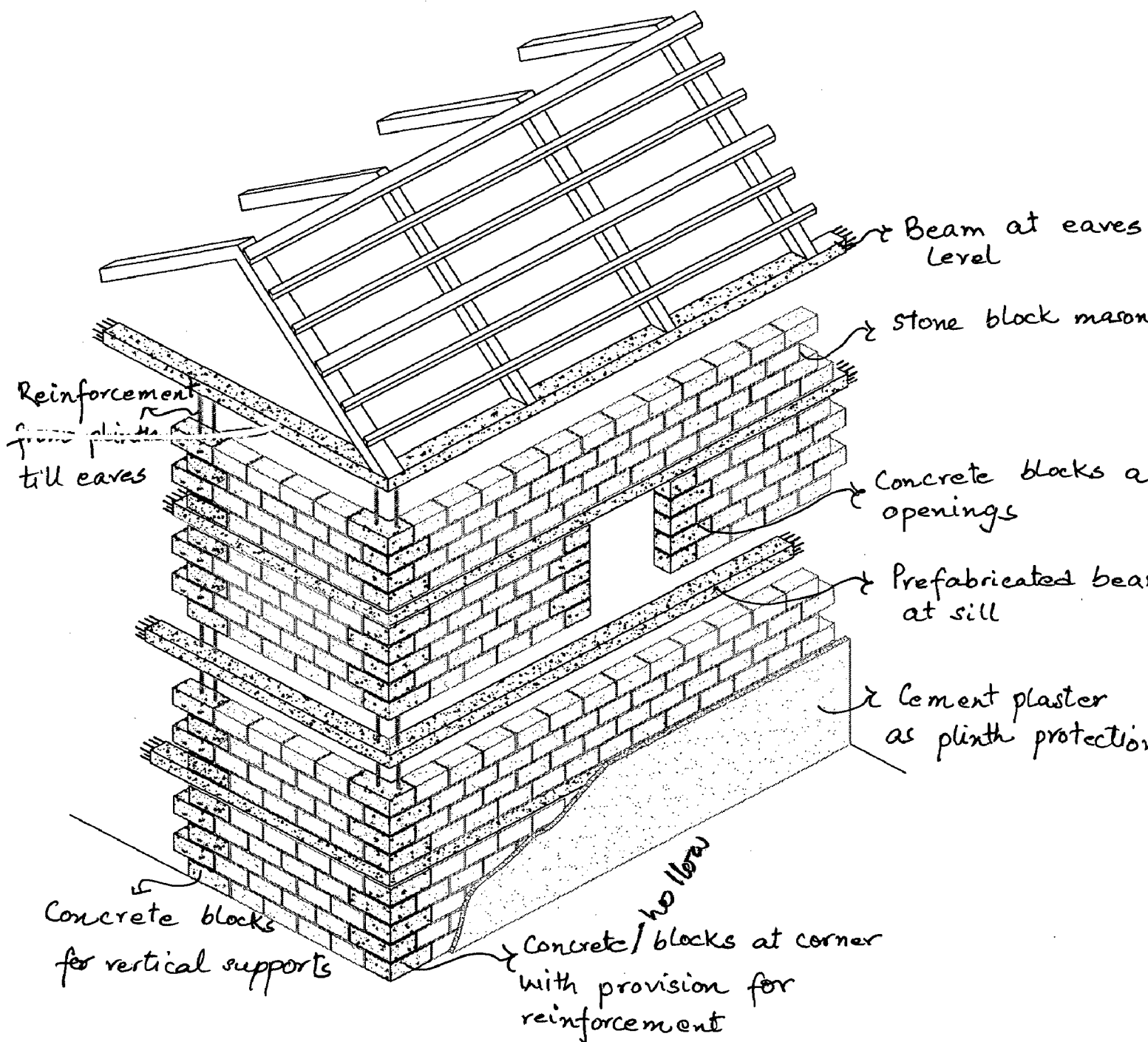

Figure 7.1 Sketch showing use of stone blocks, concrete blocks and prefabricated beams as a potential construction technique

7.5 FUTURE POTENTIAL

Traditional construction techniques in Himachal have proven to be not only climatically sensitive but safe in case of disasters too. These techniques however are not sustainable in their original form due to various limitations. However, alternate construction techniques adapt the traditional knowledge with new materials and technologies. These technologies have great potential in future since the need for a sustainable development is the need of the hour. These alternate techniques have only been used for small scale projects but in future their use for public buildings, heritage buildings, buildings for tourism can not only open new avenues for their use but can also help disseminate knowledge to the masses. Further research in this subject can be carried out for the various safety features in these alternate techniques and testing these for their sustainability for future.

REFERENCES

1. http://en.wikipedia.org/wiki/Vernacular_architecture
2. Report on BETEC symposium on “Building on a Foundation of Respect for the Environment”
3. Turner Lauren (2003), “Climate and Architecture”, Florida State University
4. http://en.wikipedia.org/wiki/Indian_ernacular_architecture
5. <http://lauriebaker.net/work/work/baker-on-laurie-baker-architecture.html>
6. Jain Minakshi, Singh Inderpal (2007), “Sustainability and traditional architecture”, Architecture- Time Space and People.
7. <http://lauriebaker.net/personal/life/india-and-gandhiji.html>
8. Serageldin Ismail (1985) “an Egyptian Appraisal”, Singapore: Concept Media
9. <http://www.unu.edu/Unupress/unupbooks/80a01e/80A01E02.htm>
10. http://archnet.org/library/sites/one-site.jsp?site_id=156
11. Rautela Piyooosh , Joshi Girish Chandra (2009) “ Earthquake safety elements in traditional Koti Banal architecture of Uttarakhand, India”, Disaster Prevention and Management, Emerald Group Publishing Limited
12. Miral M. S., Kumar Kireet and Dumka R. K. (2003), “ Traditional construction practices in the seismically active areas of uttaranchal”, ENVIS Bulletin : Himalayan Ecology
13. Desai Rajendra, Desai Rupal (2007) “Manual for Restoration and Retrofitting of Rural Structures in Kashmir”, UNESCO & UNDP
14. <http://en.wikipedia.org/wiki/Lahaul>
15. <http://en.wikipedia.org/wiki/Kinnaur>
16. <http://en.wikipedia.org/wiki/Shimla>
17. Langenbach Randolph (1992) “The earthquake resistant mud and brick architecture of kashmir” Traditional Southwest Magazine
18. Langenbach Randolph , “Conference on Intuition from the Past: What We Can Learn from Traditional Construction in Seismic Areas, Key note address”
19. <http://en.wikipedia.org/wiki/Manali>
20. http://en.wikipedia.org/wiki/Chamba,_Himachal_Pradesh
21. http://en.wikipedia.org/wiki/Hamirpur,_Himachal_Pradesh
22. http://en.wikipedia.org/wiki/Kangra,_Himachal_Pradesh#Geography

BIBLIOGRAPHY

- Abbott, D., (1980) "Hill Housing", Granada London
- Aggarwal, A., (1982) "Research: Mud as traditional building material", In The Changing Rural Habitat; Volume I: Case Studies. Brian Brace Taylor (ed). Singapore: Concept Media/The Aga Khan Award for Architecture.
- Alexander André, Catanese Andreas (2007) "The Restoration of Tsas Soma Mosque, Leh, Ladakh, India: a report", www.tibetheritagefund.org
- Baker Laurie (1986), "Houses: How to reduce building cost", COSTFORD
- Baker Laurie, (1992) "Earthquake: Report on Uttarkashi Earthquake", Department of Science and Technology
- Baker Laurie, "Brickwork", COSTFORD
- Baker Laurie, "Mud", COSTFORD
- Brunskill R.W (1970) "Illustrated handbook of Vernacular Architecture", Faber and Faber,
- Burte Himanshu., (2007) "Not by the book: Alternative approaches", The wall street journal, livemint.com
- Dasgupta Arunava, "The Himalayan Vernacular: An architectural journey towards its future".
- Desai Rajendra, Desai Rupal (2007) "Manual for Restoration and Retrofitting of Rural Structures in Kashmir", UNESCO & UNDP
- Fathy, Hassan. 1992. "Contemporaneity in the City". In Architecture for a Changing World. James Steele (ed). London: Academy Editions.
- Givoni, B. *Man, Climate and Architecture*. Amsterdam: Elsevier Publishing Company Limited, 1969.
- Handa, O.C, "Panorama of Himalayan Architecture Vol. 2", Minerava Book House Shimla.
- Holod, Renata and Darl Rastorfer. 1985. "In His Own Words". In Hassan Fathy. Singapore: Concept Media, 147-152.
- Jain, M.; Inderpal Singh; (2007) "Sustainability and Traditional Buildings", Architecture-Time Space & People
- Jain, Minakshi et al (2005) "Traditional Architecture and Planning Techniques in Himachal Pradesh", Institution of Engineers (India) Journal-AR.

- Jigyasu Rohit (2000), "From cultural to natural disaster: Consequences of post-earthquake rehabilitation process on the cultural heritage of Marathwada region, India", UNESCO-ICOMOS Conference on "Earthquake safe: Lessons to be learnt from traditional construction"
- Jigyasu Rohit (2008) "Recovering Indigenous Knowledge for Safer Schools", International Conference on School Safety, Islamabad (Pakistan)
- Kimura Ken-ichi, (1994), "Vernacular technologies applied to modern architecture", Renewable Energy, Vol.5, Part II, pp. 900-907
- KUMAR *et al.*, (1993) "Cooling techniques in a passive solar house", Energy Convers. Mgmt Vol. 35, No. 8, pp. 671-682,
- Kumar, P.S, (2009) "Breaking through the conventional barriers", epaper.dnaindia.com
- Langenbach Randolph (1992) "The earthquake resistant mud and brick architecture of kashmir" Traditional Southwest Magazine
- Langenbach Randolph (2007), "From Opus Craticium to the "Chicago Frame: Earthquake-Resistant Traditional Construction" International Journal of Architectural Heritage
- Morel J.C., et al. (2001), "Building houses with local materials: means to drastically reduce the environmental impact of construction", Building and Environment ,1119–1126
- N. Engin, N. Vural, S. Vural, M.R. Sumerkan, (2005) "Climatic effect in the formation of vernacular houses in the Eastern Black Sea region", Science Direct
- Nath Rituraj,(2010) "Assam Type House – The Traditional Earthquake Resistant Construction Practice In Assam", National Seminar on Disaster Mitigation in Housing in India.
- Pich-Aguilera, Felipe. (1989) Hassan Fathy: Beyond the Nile. In MIMAR 33: Architecture in Development. London: Concept Media Ltd.
- Rastorfer, Darl. (1985) "The Man and His Work". In Hassan Fathy. Singapore: Concept Media, 25-39.
- Representative designs of energy-efficient buildings in India, Tata Energy Research Institute
- Richardson, V. "New Vernacular Architecture", Watson-Guptill Publications

- Serageldin, Ismail. (1985) "An Egyptian Appraisal" In Hassan Fathy, Singapore: Concept Media, 15-24.
- Sharma Anupama, Dhote K K (2003) "Thermal Comfort and Heritage Building", Institute of Engineers Journal
- Sikka Sandeep, Chaudhry Charu (2009) "Climate Change in Western Himalaya Impacts, Mitigation And Adaptation Of Historic Earthen Structures", Scientific Symposium, 2009 : Changing World, Changing Views of Heritage
- Singh Manoj Kumar, (2009) "Bioclimatism and vernacular architecture of north-east India", *Building and Environment* 878–888
- Taragan, Hana. (1999) "Architecture in Fact and Fiction: The Case of the New Gourn Village in Upper Egypt". In *Muqarnas: An Annual on the Visual Culture of the Islamic World*, XVI, 169-178. Turner, L. *Climate and Architecture*, Florida State University, 2005
- Valsson Sheeba, Bharat Alka,(2008) "Climatic Considerations in planning - Inferences from past", *Architecture-Time Space & People*
- Yeomans David, (2001) "The Characteristics of Traditional Construction", Istanbul Paper.

WEBSITES

- http://en.wikipedia.org/wiki/Indian_ernacular_architecture
- <http://himachaltourism.gov.in/page/About-Himachal.aspx>
- http://en.wikipedia.org/wiki/History_of_Himachal_Pradesh
- <http://asc-india.org/menu/gquakes.htm>
- http://en.wikipedia.org/wiki/Vernacular_architecture
- http://www.arup.com/Projects/Druk_White_Lotus_School/Details.aspx
- <http://www.indiainfoweb.com/himachal-pradesh/architecture/>
- <http://lauriebaker.net/work/work/baker-on-laurie-baker-architecture.html>
- www.nbne.org/natbuild/cob.php

http://www.conservationtech.com/RL's%20resume&%20pub's/RL-publications/Equ-pubs/1989-APT-Bulletin/APT_art.htm

<http://www.unu.edu/unupress/unupbooks/80a01e/80A01E00.htm#Contents>

<http://www.saudiaramcoworld.com/issue/199904/the.legacy.of.hassan.fathy.htm>

<http://www.livemint.com/Articles/2007/10/11011246/Not-by-the-book-Alternative-a.html>

<http://www.vernarch.com/>

<http://tcdc.undp.org/sie/experiences/vol4/Rehabilitating%20indigenous.pdf>

<http://lauriebaker.net/work/work/bakers-architectural-principles.html>

<http://lauriebaker.net/work/work/alternative-building-materials-timeless-mud.htm>

http://www.dwls.org/Buildings_Photo_Gallery.html

http://www.serbianunity.net/culture/history/Hist_Serb_Culture/chk/Traditional_Architecture.html